

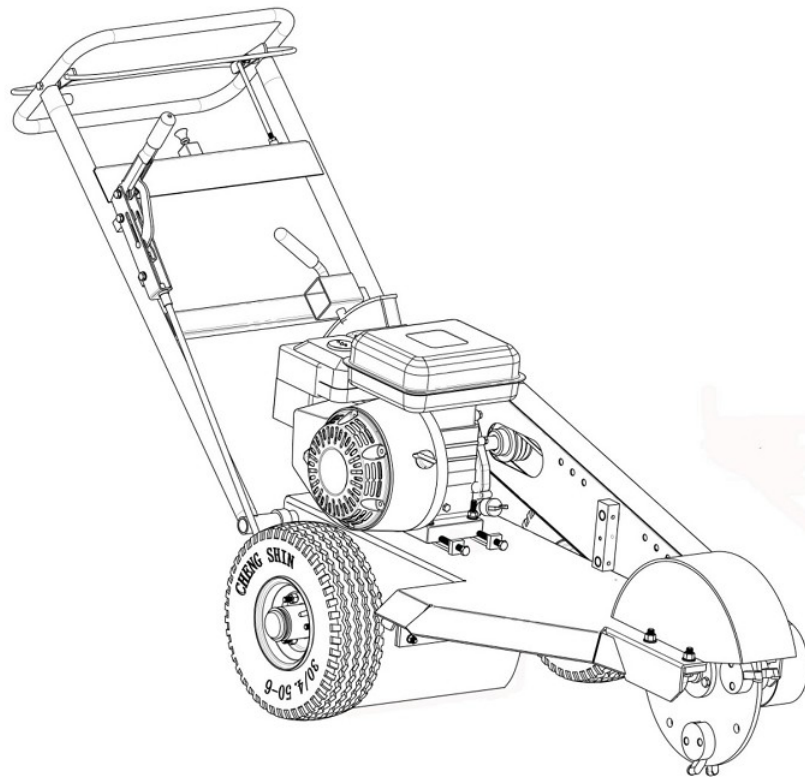

LGSG13HC

Gas Powered Professional Stump Grinder Operator's Manual



original instruction



DO NOT operate this equipment until you have read and understood all the enclosed Operator's Manual.
READ ALL the sections in this manual **PRIOR** to attempting to service, maintain or operate this equipment. !

LGSG13HC

Gas Powered Professional Stump Grinder Operator's Manual

Contents

Pre-Operation Note	1
Safety Precautions	2-3
Guide to Parts Breakdown	4
Machine Parts Breakdown	5-6
Parts List	7-9
Machine Overview	10-11
Contents List	12
Pre-Operation Procedures	13
Operation Procedures	14-16
A. Positioning the LGSG13HC	13
B. Starting the LGSG13HC	14
C. Stump grinding on level surfaces	14
D. Stump grinding below ground	16
E. Shutting down the LGSG13HC	16
Storing the LGSG13HC	16
Maintenance Procedures	17
A. Inspection Schedule	17
B. Preventative Maintenance Procedures	17
1. Cleaning the LGSG13HC	17
2. Maintenance Schedule	18
3. Lubrication Schedule	18
C. General Service Procedures	19
1. Adjusting the operator presence system	19
2. Brake adjustments	20
i. Fine travel adjustment	20
ii. High travel adjustment	20
3. Changing the teeth	21
4. Sharpening cutter teeth	22
5. Adjusting the Drive Belt	23
Information on safety decals	24



DO NOT operate this equipment until you have read and understood all the enclosed Operator's Manual.

READ ALL the sections in this manual **PRIOR** to attempting to service, maintain or operate this equipment. !

Pre-Operation Note

Thank you for your purchase of the LGSG13HC Professional Stump Grinder. This stump grinder has been designed and manufactured to our highest quality demands for durability and performance.

The LGSG13HC Professional Stump Grinder is warranted to be free from manufacturer's defects in material and workmanship for a **period of one (1) year** from the date of purchase. This warranty will be void if the machine has not been operated and maintained in the manner prescribed in this Operator's Manual. Any machine malfunctions, and/or warranty claims that arise from the misinterpretation or the misunderstanding of the instructions and cautions discussed in this booklet **will not** be eligible for warranty protection.

In order for the stump grinder to perform at its optimum capabilities, the operator must read this manual thoroughly before using this unit. This Operator's Manual contains important product operation procedures, safety precautions, maintenance and troubleshooting tips as well as other advisories. Please keep this manual both this manual and the engine manufacturer's manual in the manual storage pack, located on the handle, at all times nearby when operating the machine as a reference should any questions arise. If the machine is sold or transferred to another user, please ensure that this manual accompanies it. If the machine is sold or transferred to another user, please ensure that this manual accompanies it.

The LGSG13HC stump grinder is designed for reducing tree stumps outdoors down to a manageable size. The machine should not be used for any other purpose than that stated above. The inappropriate use of any machine can cause serious damage and/or bodily harm to the environment and operator. It is **imperative** that the operator of this equipment be **responsible** for the operational environment of the stump grinder. Please be prepared and well-informed for all specific requirements and work hazards that may and/or do exist at the jobsite.

Powered by a 13 hp HONDA engine, the LGSG13HC is a powerful unit driving tough 355mm cutter wheel with eight replaceable carbide teeth to make stump removal fast and easy. The LGSG13HC has many features which are designed to improve your working experience. The steel cutter wheel guard and heavy-duty chip curtains increase safety by shielding the operator from the cutter wheel and flying debris. A six-position adjustable handle with operator presence system maximizes comfort and ease of use. Heavy-duty inner and outer belt guards protect the operator and increase belt longevity. To extend engine life, an angled frame keeps the engine level during the grinding process. A power band belt with idler bearing provides efficient grinding. Increased stability and ease of start-up is provided by a square foot rest for pull-start models.

In order for you to enjoy the most out of your new stump grinder, always keep safety as a priority. Inspect your jobsite for any debris such as rocks, wiring, string or any other items that can become hazardous during work. Identify and mark all fixed objects to be avoided during work such as sprinkler heads, water valves, buried cables, or clothes line anchors etc. The jobsite environment, soil conditions, job specifications and operator experience will all be factors that must be considered to select the proper tool for the job. Failure to maintain the stump grinder in a proper manner will lead to decreased productivity of the tool and hazards to the operator and bystanders. **Do not use the machine if it has been modified or improperly maintained.**

All jobsites are different. Please ensure that when using the Stump Grinder, all local bylaws and codes are followed. All operators and mechanics of this machine should be trained in general machine use and safety.

Every care and effort has been made to ascertain the accuracy and completeness of procedures described in this document to ensure your enjoyment and satisfaction.

Product Specification

Model	LGSG13HC
Engine options	Honda GX390-13HP
Cutter depth below ground	229mm
Cutter height above ground	534mm
Number of teeth on cutter wheel	8
Cutter wheel diameter with teeth	355mm
Fuel tank capacity	6.1L
Tire size	5.3/4.50-6 4PR
Dimension (L×W×H)	2131 mm×800 mm×897mm
Total weight	137kgs
Noise level Lpa	83.82dB(A) Kpa=2.5dB(A)
Guaranteed noise power level Lwa	106dB(A)
Lpa at operator's position	90.9dB(A) Kpa=2.5dB(A)
Vibration acceleration value in accordance with 2002/44/EC K=1.5m/s ²	on handlebar grip $a_{hw} = 8.6m/s^2$

Safety Precautions...

1. READ AND UNDERSTAND OPERATOR'S MANUAL PRIOR TO USE OF STUMP GRINDER

2. Before operating stump grinder, ensure that it is structurally and mechanically safe by checking the following:
 - a. Are all engine controls and the clutch action functioning within acceptable tolerances?
 - b. Is the drive belt in good condition?
 - c. Are all protective guards in place?



3. Before using the STUMP GRINDER on proposed jobsite, perform the following environmental checks:
 - a. Inspect the entire work area for unexpected buried hazards, such as boulders, foundations, and fencing
 - b. Clean work area of any litter or debris, such as wire, boards, rocks, or any other potential hazards
 - c. Know and mark the location of any and all buried utility lines or sprinkler systems. If in doubt, always check with your local utilities provider for survey information and assistance.

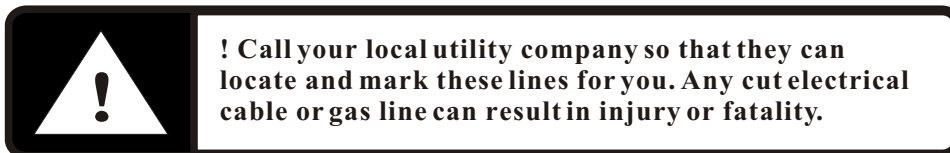

- d. Check for ventilation in work area. Do not operate the stump grinder or run the engine in unventilated areas. **ALWAYS OPERATE STUMP GRINDER OUTDOORS!!**
4. Before using the STUMP GRINDER on proposed jobsite, make sure that the operator is thoroughly familiar with the machine and its components (see "Machine Overview")
5. When operating the stump grinder, follow these guidelines for operator's personal safety:
 - a. Always wear proper safety clothing and equipment for the job. These can and should include eye and ear protection, gloves, dust mask and any other items that are appropriate for the job and jobsite requirements
 - b. Never wear any jewelry, neck ties, or other loose or hanging items that can be caught on any part of the machine
 - c. Tie back or remove any loose hair, clothing and any other potential hazards and obstructions
 - d. Keep all hands, loose clothing, hair, jewelry and all other personal parts and belongings away from moving parts of the machine.
 - e. The last operator may have been negligent and his possible oversight could cause you death or serious injury. Inspect machine before each use.
 - f. Avoid coming in contact with the muffler and other engine parts after the engine is started and the time immediately after the machine is turned off. Machine and engine temperatures may exceed 150°F or 66°C. Machine must be allowed to cool before touching it or attempting to perform any maintenance!
6. For the safety of others and that of the operator, observe the following precautions:
 - A. Keep observers and bystanders away from the stump grinder and its immediate working environment (i.e.: the tree stump that is being reduced etc.) while the stump grinder is in use.
 - b. **Stop** operations or if anyone or anything (i.e.: humans, animals, debris etc.) approaches from any direction while the machine is in operation.
 - c. **Stop** work and turn off the stump grinder if it hits any debris that jams the machine or causes it to labour unnecessarily. Inspect the stump grinder and surrounding environment for any possible causes.
 - d. If the machine is jammed, stop the engine and remove the sparkplug wire before attempting to clear any jams in the unit.
 - e. Stop all work, turn off stump grinder, unplug spark wire and ensure that engine is turned off and cooled before performing any diagnostics or repairs.

Safety Precautions cont'd

f. ROTATING STUMPGRINDER WHEEL CAN CAUSE SERIOUS INJURY OR DEATH. DO NOT ATTEMPT TO PERFORM ANY REPAIRS, SERVICE, OR DIAGNOSTICS OR TO TRANSPORT OR MOVE THE UNIT UNTIL CUTTER WHEEL HAS COME TO A COMPLETE STOP. FAILURE TO DO SO MAY RESULT IN DEATH

g. Never leave machine unattended

h. DO NOT, under any circumstances, operate machine if any of the following conditions are applicable:

- i. Any impairment (i.e.: medical conditions, medicinal side-effects, alcohol, drugs etc.) of the operator.
- ii. The operator has not read or understood the operator's manual for this machine.
- iii. The operator does not clearly understand the operations of the machine.
- iv. The machine is in need of repair
- v. The operator is inappropriately attired to operate the machine.

7. Due to the nature of the machine and the tasks that it is designed to perform, the Stump Grinder may behave in the following manner:

- a. Always start Stump Grinder a safe distance away from any object such as a fence, foundation or any other structural obstructions. The teeth could possibly catch and climb on the object.
- b. Use extreme caution when operating Stump Grinder on uneven terrain. Do not risk the possibility of causing the machine become unbalanced or rolling over.
- c. Stop operations if anyone or anything (i.e.: humans, animals, debris etc.) approaches from the front or the sides while the machine is in operation.

Danger zone

WARNING: Keep out of the stump grinder's Danger zone during starts and operation.

Check the immediate surroundings for foreign objects and for children and animals in particular!

Careful! Dirt and stones may get airborne during grinding. People and animals must keep out of this area. Watch out for vehicles, window panes and other objects to avoid damage.



Only work on slopes of up to a max. of 10°

For operation on banks, always turn machine towards the slope!

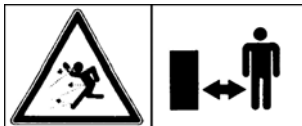

SAVE THESE INSTRUCTIONS!!

Guide to Parts Breakdown

Regular maintenance and parts replacement are important steps to extending the life of your equipment and enjoying its optimum performance. When performing or conducting any maintenance or repairs, always check that your working surroundings are safe and well-ventilated and that the technician is familiar and comfortable with all aspects of the machine and required procedures.

This guide aims to serve as a representational guide to the LGSG13HC. Any other uses or application beyond the scope of this document are strictly prohibited. While every attempt has been made to maintain its accuracy, The producer reserves the right to update and modify the equipment without prior notification. Prior to undertaking to perform any maintenance or repair procedures, please contact our Technical Support Hotline for clarification and to acquire appropriate parts.

To order spare parts, please provide the following information:

1. Machine Make
2. Model Number
3. Machine Serial Number
4. Quantity Required of Each Part
5. Part Numbers
6. Part Descriptions.

Machine Parts Breakdown

LGSG13HC

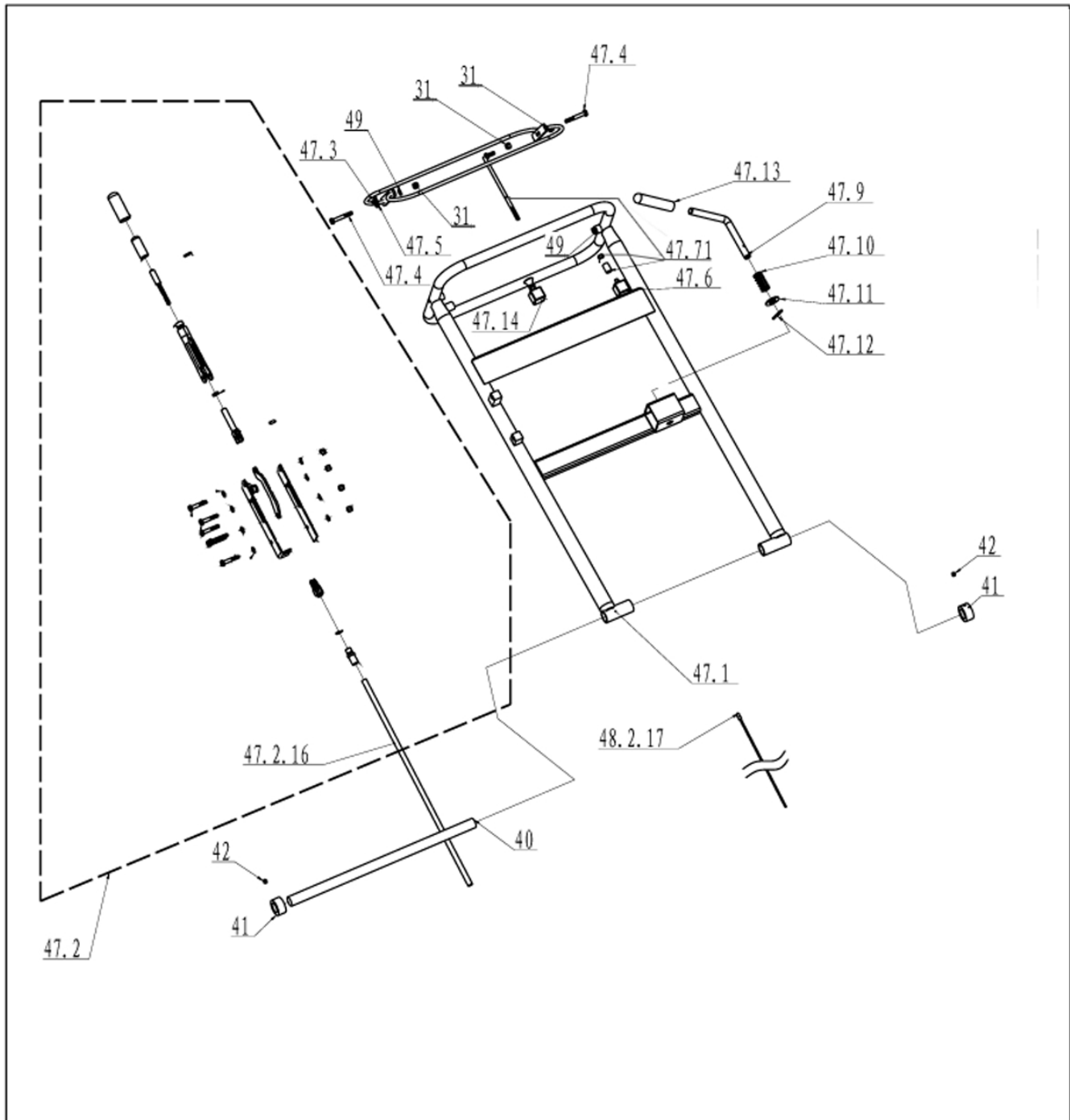

Machine Parts Breakdown

LGSG13HC

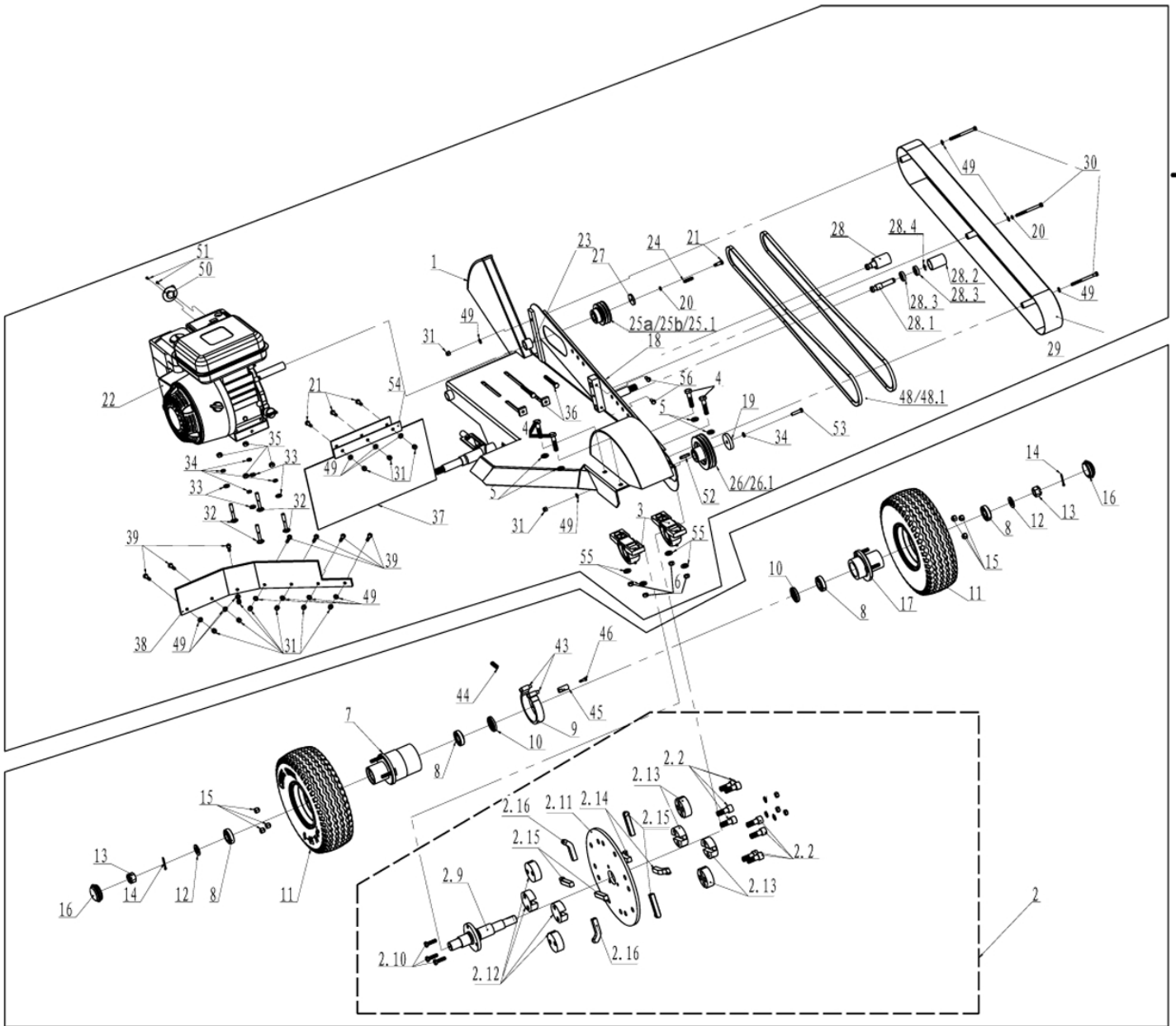

Parts List

	DESCRIPTION	Qt
ENSG13-1	chassis	1
ENSG13-2.11	cutting disc	1
ENSG13-2.2	inner hex bolt	8
ENSG13-2.12	blade bracket2	4
ENSG13-2.13	blade bracket1	4
ENSG13-2.14	blade3	2
ENSG13-2.15	blade1	4
ENSG13-2.16	blade2	2
ENSG13-2.9	spindle	1
ENSG13-2.10	hex bolt	3
ENSG13-3	spherical surface bearing sets	2
ENSG13-4	hex bolt	4
ENSG13-5	washer	4
ENSG13-6	hex lock nut	4
ENSG13-7	brake drum	1
ENSG13-8	bearing	4
ENSG13-9	brake belt	1
ENSG13-10	seal ring	2
ENSG13-11	wheel	2
ENSG13-12	washer	2
ENSG13-13	hex nut	2
ENSG13-14	cotter pin	2
ENSG13-15	nut of wheel hub	6
ENSG13-16	hub cap	2
ENSG13-17	bearing sheath	1
ENSG13-18	belt cover	1
ENSG13-19	washer	1
ENSG13-20	spring washer	2
ENSG13-21	hex bolt	4
ENSG13-22	engine	1
ENSG13-23	spacer	1
ENSG13-24	key	1
ENSG13-25.A	engine pulley tripple, up to 2012	1
ENSG13-25.B	engine pulley, tripple, 2013 LGSG13HC	1
ENSG13-25.1	engine pulley, double, 2014 and up	1

Parts List

	DESCRIPTION	Qt
ENSG13-26	pulley of cutting means, tripple, up to 2013	1
ENSG13-26.1	pulley of cutting means, double, 2014 an up	1
ENSG13-27	washer	1
ENSG13-28	guiding wheel	2
ENSG13-28.1	shaft	2
ENSG13-28.2	wheel	2
ENSG13-28.3	bearing	4
ENSG13-28.4	check ring	2
ENSG13-29	belt cover	1
ENSG13-30	hex bolt	3
ENSG13-31	hex lock nut	19
ENSG13-32	square neck bolt	4
ENSG13-33	washer	7
ENSG13-34	spring washer	5
ENSG13-35	nut	4
ENSG13-36	hex bolt	2
ENSG13-37	rear deflector	1
ENSG13-38	front deflector	1
ENSG13-39	hex bolt	7
ENSG13-40	handle pivot	1
ENSG13-41	spacer	2
ENSG13-42	inner hex lock screw	2
ENSG13-43	brake sliding pin	2
ENSG13-44	brake spring	1
ENSG13-45	brake cable clamp	1
ENSG13-46	hex bolt	1
ENSG13-47	handle assembly	1
ENSG13-47.1	handle	1
ENSG13-47.2	wheel brake handle assembly	1
ENSG13-47.2.16	cable sheath	1
ENSG13-47.2.17	cable	1
ENSG13-47.3	control lever	1
ENSG13-47.4	hex bolt	2
ENSG13-47.5	spring	1
ENSG13-47.6	switch	1

Parts List

	DESCRIPTION	Qt
ENSG13-47.8	switch linkage Assembly	1
ENSG13-47.9	pin	1
ENSG13-47.10	spring	1
ENSG13-47.11	washer	1
ENSG13-47.12	cotter pin	1
ENSG13-47.13	grip	1
ENSG13-47.14	switch	1
ENSG13-47.15	nut	1
ENSG13-48	belt, 3 x single, good for pulley ensg13-25 or ensg13-	1
ENSG13-48.1	belt, 2 x single, ideal for pulley ensg13-26,1	1
ENSG13-49	washer	25
ENSG13-50	elbow	1
ENSG13-51	cross slot ST screw	2
ENSG13-52	key	1
ENSG13-53	hex bolt	1
ENSG13-54	clamp	1
ENSG13-55	washer	4
ENSG13-56	hex bolt	2

Machine Overview

The following is a list of important control and operation mechanisms with which the operator must be familiar PRIOR to using the stump grinder. Failure to do so may result in severe injury and/or fatality to the operator and others and may lead to reduced machine life or damage to the stump grinder.

- a. Start/stop switch- The Start/stop switch is located on the control panel that is attached to the handle. The Start/stop switch turns on and off the machine. Pull the switch to start the machine and push it to stop the machine. In the event of an emergency, push the Start/stop switch immediately!
- b. Operator presence loop- The operator presence loop enables the engine to run when the operator presses either end of the loop against the handle of the machine. This design is a safety mechanism which functions as a dead man's grip. Releasing the loop will deactivate the engine so as to disengage the stump grinder when there is no operator or other external force to engage the loop.
- c. Brake Lever Handle- The brake lever handle locks the braked wheel. Shift the brake lever handle into an upright position to lock the braked wheel.
- d. Heavy-Duty chip Curtains- The chip curtains protect the operator from flying debris. Do not operate the stump grinder if chip curtains are frayed, torn, or missing.
- e. Square Foot Rest- The square foot rest increases the stability of pull-start models. To start a pull-start model, place foot on square foot rest while pulling on starter rope and pushing down on handle.
- f. Handle Height Adjusting Pin- The handle height adjusting pin allows the operator to adjust the handle for comfort or different job conditions. Caution: Do not attempt to adjust handle height while engine is running or cutter wheel is rotating.
- g. Belt Guards- The belt guards protect the operator and extend belt life. Before using the stump grinder, operator should ensure that belt guards are secure and in good condition.
- h. Cutter Wheel Housing- the cutter wheel housing is a metal shell that covers the top of the cutter wheel. Before using the stump grinder, operator should ensure that the cutter wheel housing is secure and in good condition (e.g., free of cracked welds, dents, and thin spots).
- i. Cutter Wheel Assembly must be kept in good condition (e.g., with sharp teeth, all bearings and pocket bolts securely in place, and good pocked condition).

Machine Overview cont'd...

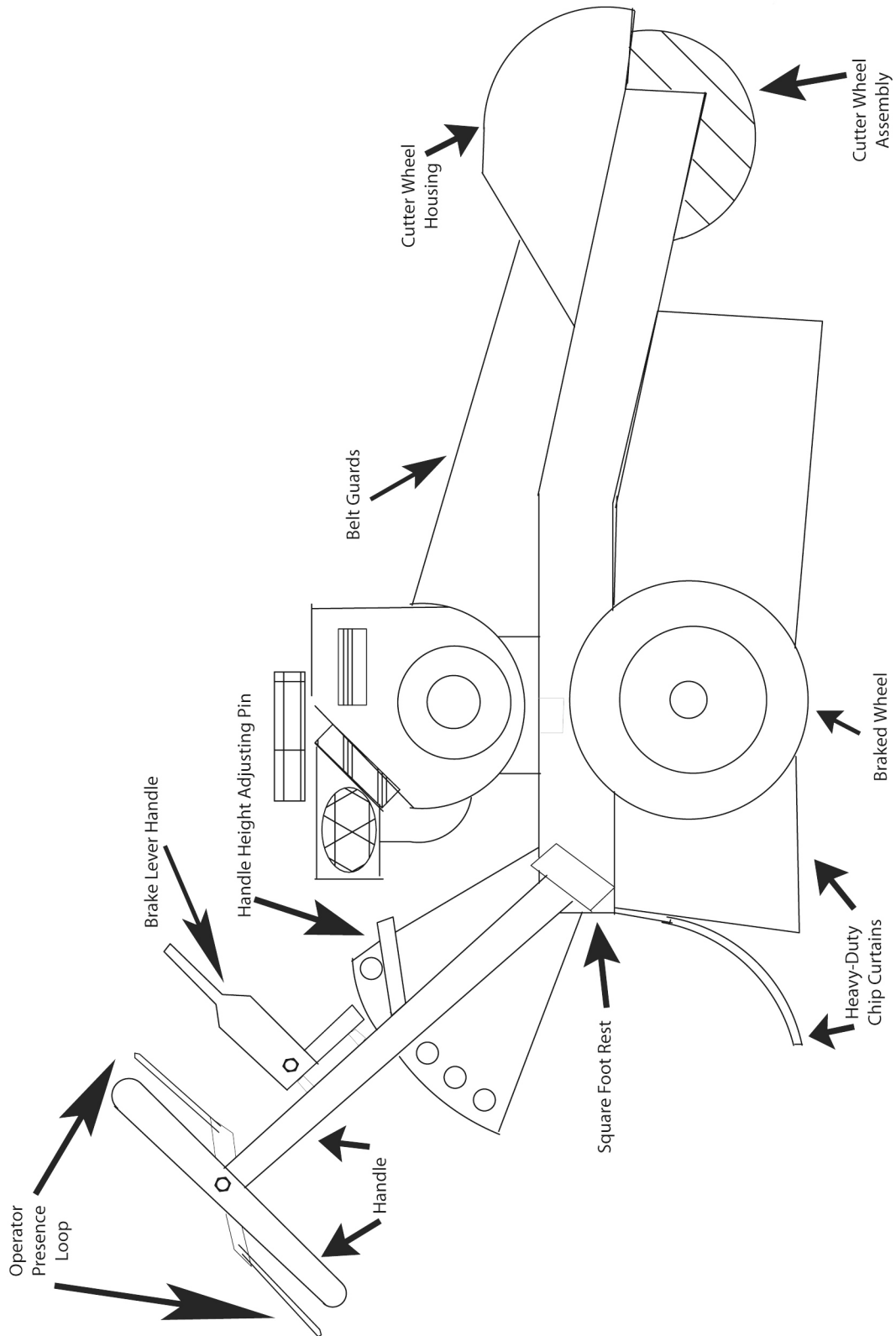

Contents List



Prior to setting up the LGSG13HC Professional Stump Grinder, check that the following items are enclosed:

item	quantity	check if enclosed
LGSG13HC Professional Stump Grinder Unit	1	____ Yes ____ No
Stump Grinder Operator's Manual	1	____ Yes ____ No
Original Engine Manufacturer's Manual	1	____ Yes ____ No

If any of these items are missing, please contact your local dealers

DO NOT ATTEMPT ASSEMBLY OR OPERATION WITHOUT ANY OF THESE LISTED PARTS!

Pre-Operation Procedures

Before using the LGSG13HC **Professional Stump Grinder**, please perform the following procedures for the personal and property safety of the operator and jobsite and for optimal performance.

1. Before operating the **Stump Grinder** ensure that it is structurally and mechanically safe by checking the following:
 - a. Perform a detailed visual inspection on the machine with particular attention to the following:
 - i. Are there any loose, worn or damaged parts? If so, **DO NOT ATTEMPT TO OPERATE THE MACHINE**. Make note of required parts, and contact your local dealer for replacement parts and further assistance to service the unit **PRIOR** to any further use.
 - ii. Is the machine, particularly the cutting wheel and teeth, clean and free of debris? Small rocks and other foreign objects can jam machine and cause the unit to malfunction, leading to serious injury to the operator and property damage on the jobsite.
 - iii. Are there any cracks or damage on the engine? Consult with the engine manufacturer's manual for guidelines and instructions on service. **DO NOT ATTEMPT TO OPERATE THE MACHINE** until engine is refurbished to engine factory standards.
 - b. Inspect the handle for the following:
 - i. Is the handle properly and securely attached to the machine?
 - ii. Is the handle set in a comfortable position for the operator? Only use machines that the operator can control easily and comfortably. Consult your local health and safety organization for any pointers for jobsite and machine operation safety.

Pre-Operation Procedures cont'd...

2. Before operating the **Stump Grinder**, perform the following environmental checks:
 - a. Will the machine be operation at ground level or will it be removing a stump below ground level? Refer to the section "**Stump Grinding Below Ground Level**" under the "Operation Procedures" section of this manual for further details.
 - b. Has the **work area been** cleared of debris such as string, wire, rocks, metal and other materials? Such items could cause malfunction or damage to the **Stump Grinder** that could also be potentially hazardous to the machine and operator.
 - c. Are all obstructions such as sprinkler lines, electrical boxes, fences etc. clearly marked?



If any of the above checks fail, please take necessary steps to maintain or repair the unit before operating it in any environment.

Operation Procedures

A. Positioning the LGSG13HC

1. Ensure that the stump grinder is completely turned off prior to adjusting or relocating the unit.
2. Position the cutter wheel above the top edge of the stump that is closest to you (see Point A, Figure 1)
3. While standing behind the operator presence loop, lock brake wheel by pulling brake lever handle toward you (see Point B, Figure 1)
4. After positioning Cutter Wheel, adjust handle height for maximum comfort, stability, and safety.

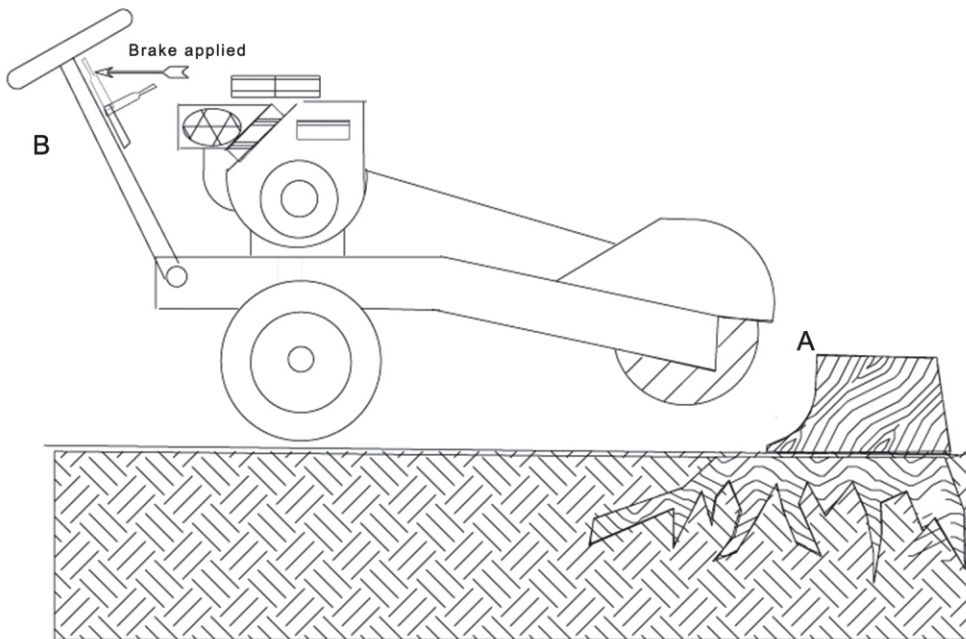



Fig.1: Positioning the LGSG13HC

Operation Procedures cont'd...

B. Starting the LGSG13HC

1. Ensure that the cutter wheel off the ground before starting engine. Follow instructions in the engine manufacturer's manual to properly start the engine.
2. Start the machine by pulling the start/stop switch located on the control panel.
3. Grasp the operator presence loop and press it tightly against the handle.



Machine will not operate unless operator presence loop is pressed against the handle. Releasing the loop will disable the machine (see Figure 2)

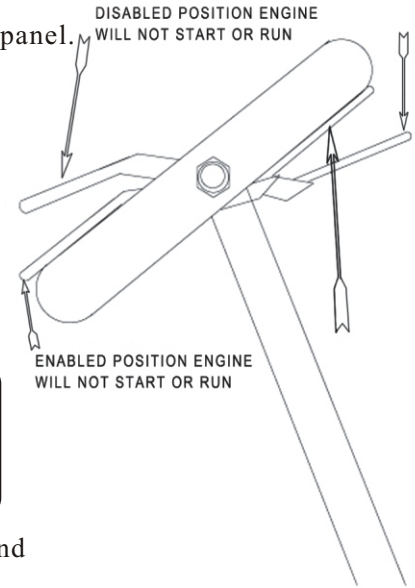



Fig.2: Using the operator presence loop



DO NOT TAMPER WITH OR DISABLE OPERATOR PRESENCE SYSTEM. IF ENGINE RUNS WITH OPERATOR PRESENCE LOOP IN DISABLED POSITION, DO NOT USE MACHINE UNTIL IT IS REPAIRED.

4. Activator engine by pulling cord while resting foot on square foot rest and pushing down on handle, see engine manufacturer's manual for further instruction on how to start engine.

C. Stump grinding on Level Surfaces

1. Allow engine to warm up to operating temperature (see engine manufacture's manual). Increase speed to full throttle once engine is sufficiently warm.
2. With handle parallel to the ground, start cutting process by moving the handle right to left and back to right.
3. Move the cutter wheel over the stump, removing 1/2" to 3/4" with each pass of the cutter wheel (See figure 3)

DO NOT TAKE LARGE PASSES. DOING SO MAY BOG DOWN THE ENGINE.

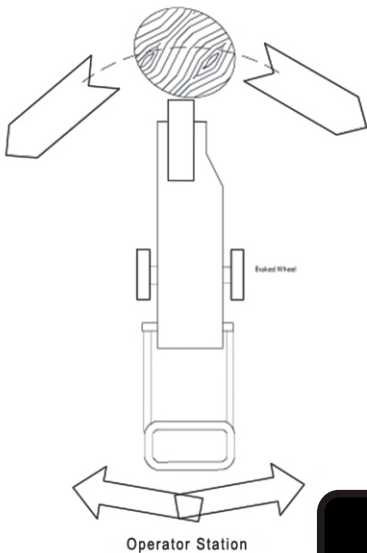
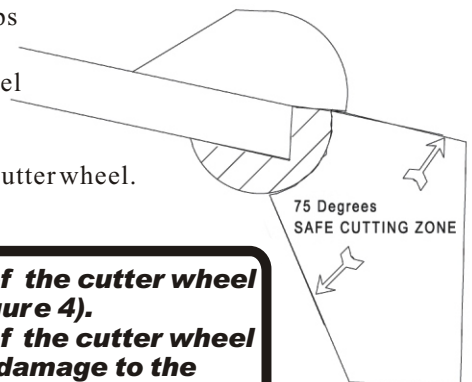



Fig.3: Proper method of grinding down tree stumps

4. Verify that only the safe area of the cutter wheel is in use for cutting (Figure 4)

Fig.4: Safe cutting zone on cutter wheel.

Use only the safe cutting zone of the cutter wheel to cut and grind stumps (see Figure 4). Cutting with any other portion of the cutter wheel may result in operator injury or damage to the machine.

Operation Procedures cont'd...

5. If there is a need to reposition the stump grinder, follow these directions:
 - a. Release the operator presence loop and press the start/stop switch to turn the machine off and follow the engine manufacturer's instructions on shutting down the engine. Ensure that the cutterwheel has come to a complete stop. **NEVER LEAVE A RUNNING STUMP GRINDER UNATTENDED.**
 - b. Remove the stump grinder away from work area and set the break lever.
 - c. Clear the work area of any wood chips or debris prior to repositioning the stump grinder.

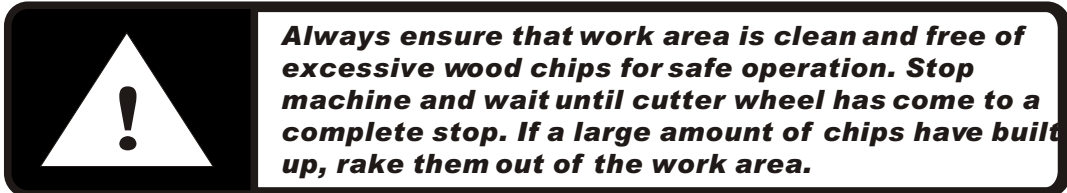

- d. Release break lever, reposition the machine to the remaining outside edge of the stump (see Figure 5).
- e. Apply brake, start engine and machine as previously described and continue to grind the stump until it is level with the ground.
- f. Repeat process until entire stump is level with the ground (see Figure 6).

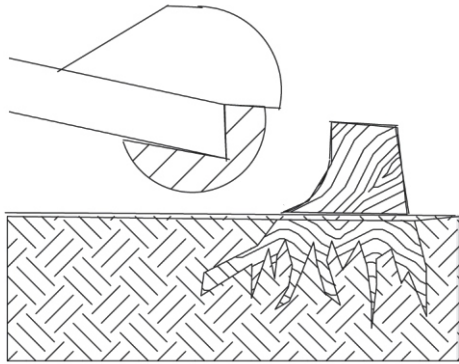

Fig. 5 Positioning cutter wheel to outside edge of stump

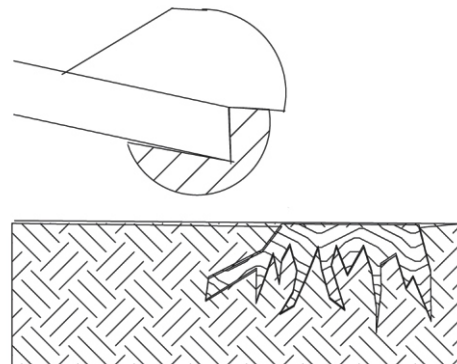

Fig. 6 Grind until stump is level with ground



- g. If a large quantity of chips have built up in work area, stop the machine and clear work area of chips and foreign objects.

Operation Procedures cont'd ...

D. Stump grinding below ground.

1. Stop machine, release brake.
2. Reposition machine and handle to ensure maximum stability and comfort during below-ground cutting.
3. Apply brake, start engine and press cutting zone of cutter wheel into stump.
4. Remove stump with back and forth motion that is described in section C (see Figure 7)

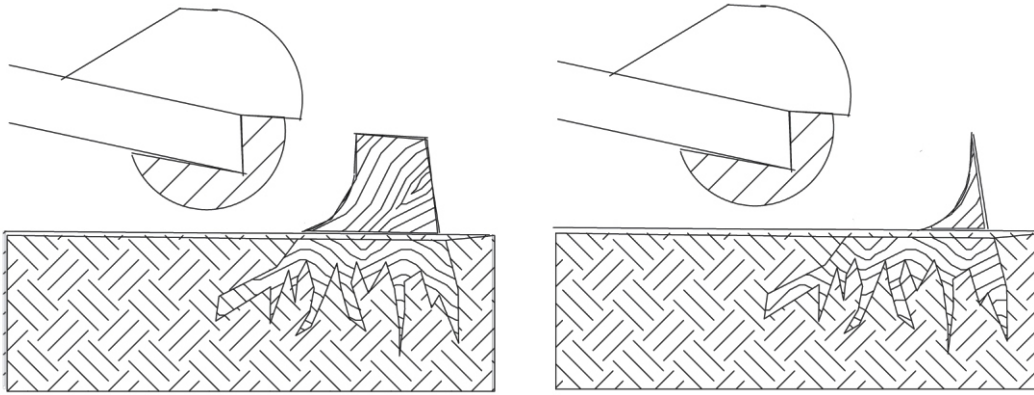
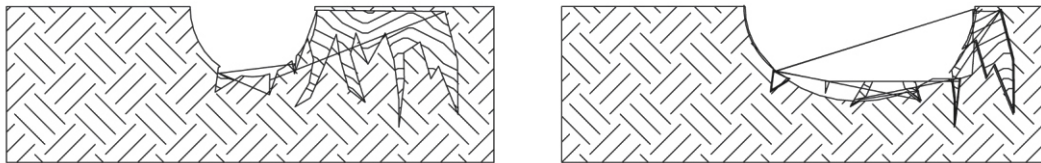

Fig.7: Stump grinding below ground level



E. Shutting down the LGSG13HC

1. Place throttle in slow position and then stop engine by pushing start/stop switch on control panel.
2. Shut down engine as per engine manufacturer's instructions and remove key if so equipped.
3. After engine cools, remove dirt chips and other foreign debris from the machine.



***The rotating cutter wheel is dangerous.
Operator must stand at the controls until the cutter
wheel comes to a complete stop.***

Storing the LGSG13HC

1. Ensure that the area in which the machine will be stored is well-ventilated and free of any potential fire hazards such as open flames, gas appliances, furnaces, water heaters, and other appliances.
2. Clean and lubricate machine prior to storage.
3. Lightly lubricate flails and rotor to inhibit rusting.
4. Touch-up any scratches or damaged area exposing metal to the elements.
5. Order and re-apply any safety labels. Refer to "Information on Safety Decals" in "Parts Breakdown Section" of the manual for placement and parts numbers.
6. Verify with engine manufacturer's handbook for guidance on preparing engine for storage.
7. Store unit in transport position (see "Transporting the LGSG13HC" in "Operation Procedures" section)
8. Store the machine in a covered or indoor storage area for increased protection and longevity.

Maintenance Procedures

This section encompasses two general types of maintenance: 1. Preventative Maintenance and 2. General Service. The first refers to regularly scheduled routine care of the stump grinder, such as cleaning and lubrication. The second provides information on common procedures, such as changing flails, and adjusting the drive belt that are to be performed as needed.

By following the Inspection Schedule below BEFORE and AFTER each use of the stump gringder appropriate actions can be taken to extend the service life of the machine and reduce any costly repairs and unnecessary downtime for the unit.



! All service should be performed by trained technicians.

A. Inspection Schedule

The following list aims offer some basic guidelines to performing a detailed inspection BEFORE and AFTER each use. Certain checks will require some disassembly, i.e. the removal of the drive guard, to perform. Depending on various environmental conditions and frequency of use, other inspection points may have to be added for each machine.

Item	Yes	No
Is the engine oil filled to recommended levels? Consult Engine Manufacturer's Manual.		
Is the gear box well lubricated and clean?		
Is the engine air cleaner properly attached and clean? Consult Engine Manufacturer's Manual.		
Is the drive belt tension set properly?		
Is the splitting wedge well-sharpened and in good repair?		
Are the safety warning labels and other decals clearly identifiable and legible? If not, ensure that fresh decals will be re-applied prior to use for operator safety.		

B. Preventative Maintenance Procedures

Maintaining a regular cleaning and lubrication schedule as well as taking time to perform preventative maintenance procedures will prolong the service life of the LGSG13HC. The following are guidelines to setting up a regular maintenance routine for the stump gringder

1. Cleaning the LGSG13HC

- i. After each use, the stump grinder, in particular the cutting wheels, cutting teeth and underneath the rubber skirt, should be cleaned and washed of any dirt or debris that may be trapped in the unit.
- ii. When using a power pressure washer to clean the unit, DO NOT USE ANY MACHINE RATED HIGHER THAN 1000 PSI.
- iii. Beware of damaging any warning decals and labels, as well as the drive belt, bearings and engine. Limit direct spray on these objects to help prevent their wear and tear.
- iv. For easier access to cleaning the stump grinder, the machine may be tipped on its engine guard for NO MORE THAN 2 MINUTES. Engine damage may result from gasoline flowing into the crankshaft due to prolonged tipping.

Maintenance Procedures cont'd ...

2. Maintenance Schedule

Item to check	10 Service Hours	15 Service Hours	25 Service Hours	50 Service Hours	Every Six Months
Operator Presence System	✓				
Brake Adjustment	✓				
Teeth and Cutter Wheel Assembly	✓				
Tires and Chip Curtains	✓				
Walk Around Inspection	✓				
Wires and Cables	✓				
Bolts and Mounting Hardware	✓				
Safety Labels	✓				
New Drive Belt		✓			
Grease Cutter Shaft Bearings			✓		
Drive Belt Tension				✓	
Wheel Bearings					✓

3. Lubrication Schedule

Regularly scheduled lubrication of the LGSG13HC is essential to smooth performance and extended equipment life. The following schedule is a recommended guide to lubricating your LGSG13HC. The schedule should be adjusted for various environmental conditions and frequency of use.

Item	Suggested lubricant	Every 20 hours	Every 60 hours	As required	After each pressure wash	storage
Engine	Refer to owner's manual for Engine			✓		
Wheel	Lithium-based Grease		✓	✓	✓	✓
Cutting Teeth, Pockets & Wheel	General purpose spray lubricant			✓	✓	✓
Zerks	General purpose spray lubricant			✓	✓	✓



Technician should read and thoroughly understand all manuals pertaining to the machine to be serviced. Do NOT proceed with any service and maintenance activity until ALL questions and concerns have been addressed. Please call your local dealer for technical support and advice.



! ALWAYS consult and verify that all local codes and bylaws are followed before performing any service or maintenance procedures.

Maintenance Procedures cont'd ..

C.General Service Procedures

The following are general guidelines for servicing common wear components on the LGSG13HC Stump Grinder. ALL MAINTENANCE AND SERVICE WORK MUST BE PERFORMED BY A TRAINED AND EXPERIENCED TECHNICIAN. Ensure that the work area is clean and free of debris prior to starting any maintenance or service work. Small particles may become trapped in key components that may lead to serious damage to the machine and cause severe bodily harm to the operator or technician.

Before performing any service and maintenance procedures, consult these general safety procedures for a safe working environment.

1. Make sure that both the engine and stump grinder are cool prior to any service or maintenance work.
2. Verify that work area is clean and free of any debris, tripping or fire hazards, and other potential sources of danger.
3. Always wear proper safety clothing and equipment for the job. These can and should include eye and ear protection, gloves, dust mask and any other items that are appropriate for the job and jobsite requirements
4. Ensure that the technician has tied back or remove any loose hair, clothing and any other potential hazards and obstructions
5. Block the wheels.
6. Disconnect spark plug.

1 Adjusting the operator presence system

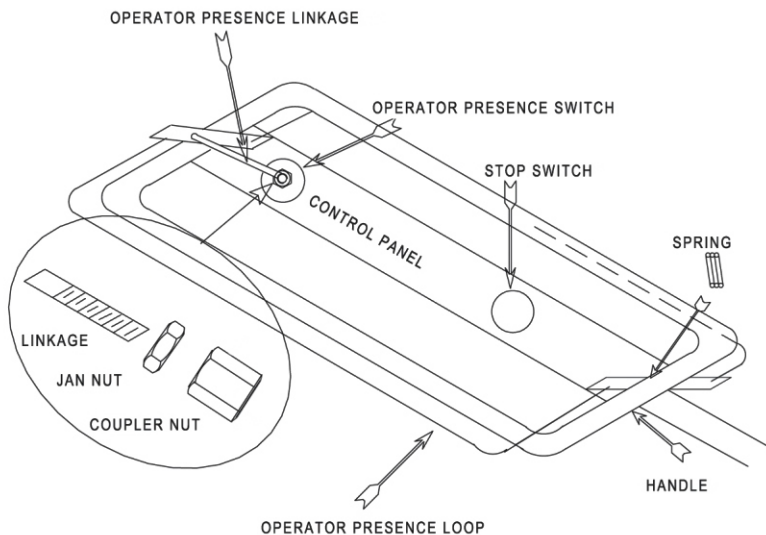

By adjusting the linkage, the operator presence system can be tuned for increased responsiveness.

- i Loosen the jam nut.
- ii Adjust the coupler nut to obtain proper interaction with the operator presence switch.
- iii The switch should click with a slight movement of the operator presence loop.
- iv Tighten the jam nut.
- v Verify that stop switch is working before putting machine into service.

The Operator Presence System (see Figure 8) pictured consists of:

- i. Operator Presence Loop
- ii. Linkage
 - 1 Lock nut
 - 2 Rod
 - 3 Jam nut
 - 4 Coupler Nut
- iii. Operator Presence Switch
- iv. Stop Switch
- v. Return Spring
- vi. Wiring Harness

Fig. 8 Operator presence system

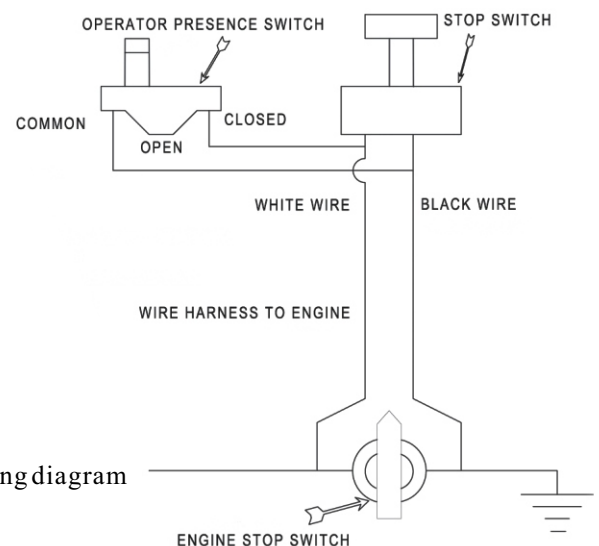
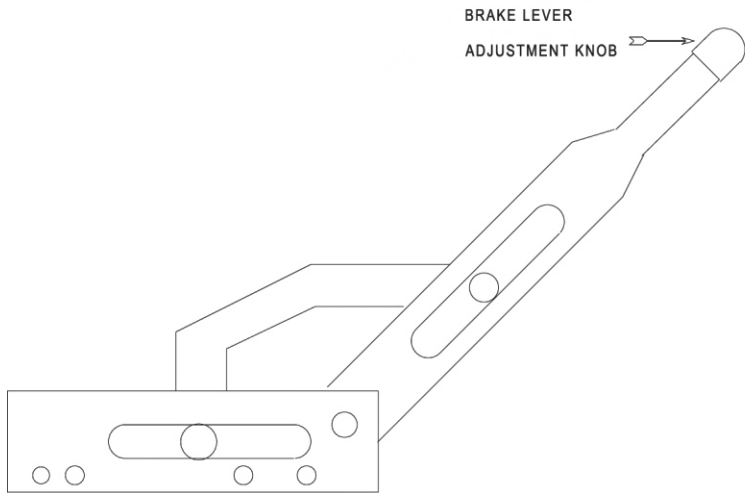

Fig. 9 Operator presence system wiring diagram

Maintenance Procedures cont'd ..

2 Brake adjustments

The LGSG13HC Stump Grinder is designed to permit both fine and high travel brake adjustment. During adjustment, inspect all parts and replace any that are worn or damaged.



i. Fine travel adjustment

- Place brake lever handle in released position.
- Turn brake lever adjustment knob one turn in a clockwise direction.
- Check operation. If wheel does not lock completely, repeat the above steps.

Fig. 10: Brake lever adjustment.

ii. High travel adjustment

- Place brake lever handle in released position.
- Turn brake lever adjustment knob as far as it will go in a counter-clockwise direction (see Figure 10). Return brake lever adjustment knob six turns in a clockwise direction.
- Loosen set screw in cable clamp (see Figure 11).
- Pull end of inner brake cable through floating pins, spring, and cable clamp until there is no slack in the cable.
- Tighten set screw in cable clamp (see Figure 11).
- Check operation. If wheel does not lock completely, readjust.

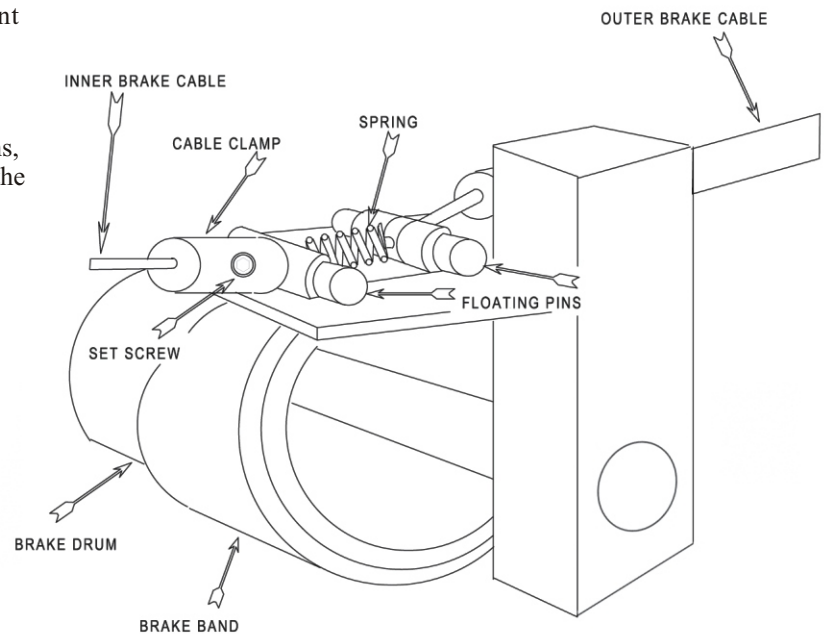

Fig.11 Brake assembly

Maintenance Procedures cont'd ..

3. Changing the teeth



Do not proceed with tooth removal until engine is cool. Do not change teeth until the engine has been disabled. Disable engine by removing key from switch and then removing spark plug wires and battery cable. Be sure to wear personal protective equipment.

- i. Clean all dirt from cutter wheel assembly. Refrain from pounding on the tips of the teeth. The tips are made put of carbide, which will chip if struck.
- ii. To prevent cutter wheel from turning, place a pin that is 5/8 in diameter in holding pin hole (see Figure 12)
- iii. Loosen packetbolts with allenwrench, socket, and breaker bar.
- iv. Remove all parts, clean and inspect. Replace any worn or damaged parts, including the cutter wheel shaft, bearings, and cutter wheel.
- v. Sharpen (see instructions that follow) or replace stump teeth as needed. Replacement teeth may be obtained from your local dealers.
- vi. Reassemble cutter wheel assembly. Use tooth gauge to position teeth such that they follow the cutter teeth pattern (see Figures 13 and 14). Make sure that all cutting edges of teeth are the same distance from the cutter wheel. **All teeth must be on wheel to keep it balanced. The same style packets must be used to keep wheel balanced.**
- vii. Use anti-seize compound on pocket bolt threads. Torque packet bolts to 110-ft. Lbs.

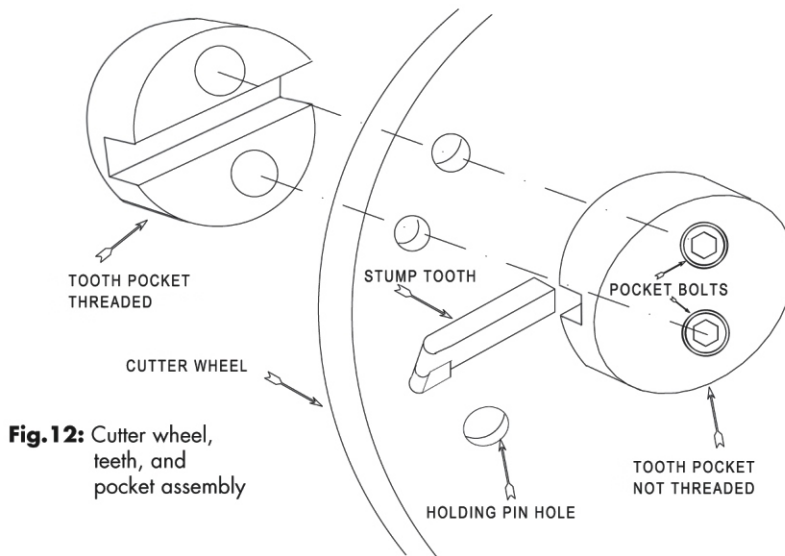

Fig. 12: Cutter wheel, teeth, and pocket assembly

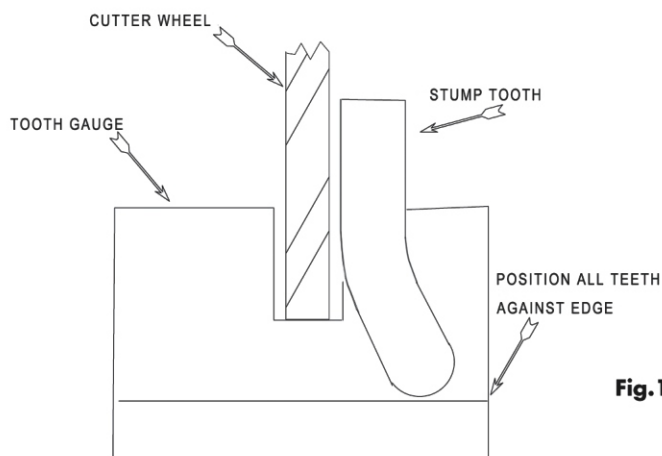

Fig. 13: Using the tooth gauge to properly position grinding teeth

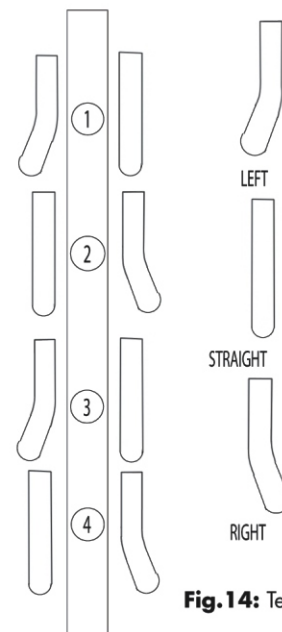

Fig. 14: Teeth installation pattern

Maintenance Procedures cont'd ..

4. Sharpening cutter teeth



Sharpening stump grinder teeth produces dust that is hazardous to people and animals. Do not sharpen teeth in the absence of a dust collection system and adequate ventilation. Cutting tools may shatter if they are misused. Be sure to use shields and eye protection when sharpening or in the vicinity of sharpening.

Stump grinder teeth have a carbide tip that is silver soldered to a steel base. The carbide tip is what actually cuts the stump. The tip also shields the steel beneath it from being worn away. Maintaining the sharpness of the carbide and keeping down relief at 10 degrees (see Dimension A, Figure 15) will result in a machine that cuts more efficiently than a machine that has dull teeth.

To sharpen the tooth properly, you must use two different wheels – one wheel for the carbide and another for the steel. The procedure for sharpening teeth is as follows:

- i. Use the steel grinding wheel to grind away some of the steel that is beneath the carbide tip. Grind steel at a 12 degree angle (see Dimension B, Figure 15)
- ii. Use the carbide wheel to grind the carbide at a 10 degree angle (see Dimension A, Figure 15).
Grind until the carbide does not overlap with the steel and the top edge of the carbide is sharp.
- iii. Teeth may be sharpened as long as 3/8 of carbide remains on the tip (see Dimension C, Figure 15).
Replace any tooth that has less than 3/8 of carbide left.

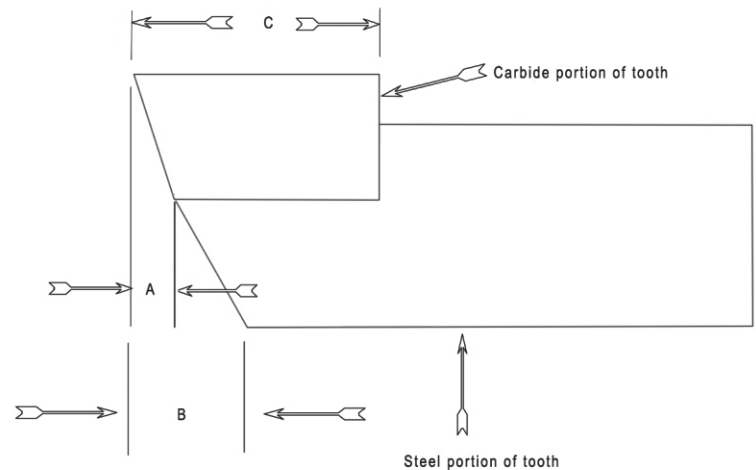

Fig. 15: Guide to sharpening grinding teeth



Do not attempt to cool stump grinder tooth after grinding by immersing it in water. Immersing hot tooth in water may cause carbide to crack.

Maintenance Procedures cont'd ..

5 Adjusting the drive belt

Do not proceed with drive belt adjustment until engine is cool. Do not adjust drive belt until engine has been disabled. Disable engine by removing key from switch and then removing spark plug wire and battery cable. Be sure to wear personal protective equipment.

If it is needed to replace drive belt, please contact your local dealer for details.



New belts have a break-in period and must be checked after 15 hours of use.

INFORMATION ON SAFETY DECALS

Below are the decals available for re-ordering to facilitate maintenance. All decals are available for replacement except that with the serial number of the unit for each number serves as a unique identifier for warranty and support purposes.

If you have any questions, please do not hesitate to contact your local weibang authorized dealer for further assistance.

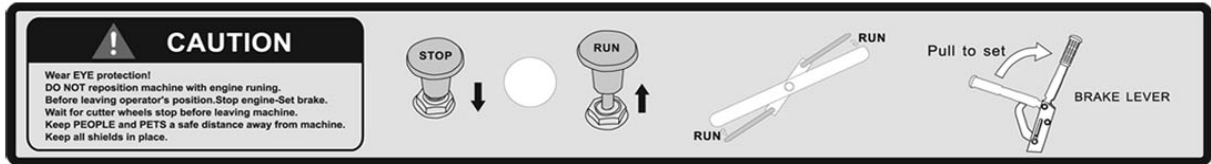

OPERATION: PART NO. DSZLP020
QTY Required=1PCS



CAUTION: PART NO. L0106090
QTY Required=1PCS

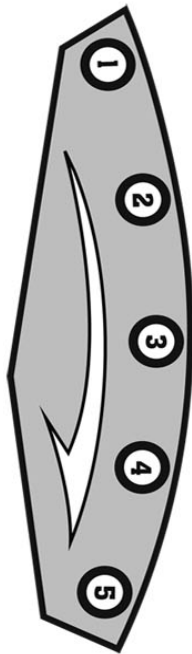

POSITION:
PART NO. DSZLP010
QTY Required=1PCS



FUEL TANK:
PART NO. L0106040
QTY Required=1PCS



WARNING: PART NO. L0203000
QTY Required=1PCS



BELT SHIELD: PART NO. L0106080
QTY Required=1PCS



HANDLE BAR: PART NO. L0106050
QTY Required=1PCS



LOGO: PART NO. L0401050
QTY Required=1PCS

