

# ***Dynablast***<sup>TM</sup>

## **Operating manual**



**HV700FLS**

**HV900FLS**

**Dynablast** Division of John Brooks Company Limited  
2625 Meadowpine Blvd, Mississauga, Ontario L5N 7K5  
Ontario/Quebec/Maritimes Tel: 888-881-6667  
Alberta/Manitoba/Sask/B.C. Tel: 800-527-8592  
www.dynablast.ca 4/19 rev 2

## Table of Contents

Safety Considerations and Warnings	2
Pre-operating Instructions	3
Connecting Operating instructions / Burner Setup	4-5
Operating Instructions	6-7
Maintenance	8-9
Specifications	10
Troubleshooting	11-14
Warranty policy	15
Service Bulletin	16
Illustrated Parts List	17-24
Electrical wiring diagram	25

## **SAFETY CONSIDERATIONS AND WARNINGS**

Please read this manual completely before installing or operating your Dynablast pressure washer or steam cleaner.



**Professional Service Required:** Incorrect installation or misuse of this equipment could result in server personal injury or death from heavy smoke, fire or explosion.



**Nocuous gas hazard:** Never run the unit in an enclosed area. Exhaust fumes contain carbon monoxide a poisonous, odorless, tasteless, invisible gas that can lead to loss of life. Always ensure this machine has proper ventilation for both the exhaust gases and the required combustion air.



**Explosion hazard:** This machine is designed to work with No.1 or No. 2 fuel oil. Never use gasoline, crankcase oil, or any oil that might contain gasoline. An explosive condition could result.



**Water injection hazard:** High pressure water if directed at any part of your body can tear through skin this can lead to water injection, which is a very dangerous condition that can lead to loss of limb, or even loss of life. Never direct high pressure spray towards persons or animals.



**Burn hazard:** This machine has the ability to product super heater water (steam). As a result all components downstream of the heater module will be extremely hot. Care needs to be observed when handling parts of this machine, to avoid burns. Always wear protective clothing (gloves, long sleeves and pants, protective eyewear safety shoes...etc)



**Shock hazard:** Never direct high pressure spray towards any live electrical equipment or outlets. A severe shock and personal injury may result



**OUTDOOR USE ONLY!**



**DO NOT USE GASOLINE, CRANKCASE DRAININGS, OR OIL CONTAINING GASOLINE OR SOLVENTS**



**THIS MACHINE IS NOT TO BE CONNECTED TO A TYPE “B” GAS VENT**



**WARNING: RISK OF INJECTION OR SEVERE INJURY. KEEP CLEAR OF NOZZLE. DO NOT DIRECT DISCHARGE STREAM AT PERSONS. THIS EQUIPMENT IS TO BE USED BY TRAINED OPERATORS**

## **PRE-OPERATING INSTRUCTIONS**

Arrange with a qualified electrician to install a properly grounded, if negative & positive power wires lengths are extended increase gauge size of wire.

Protect the receptacle from splashes, the recommended high above the ground is a minimum four feet, or as recommended by the local code.

A ground fault circuit interrupter (GFCI) is highly recommended for any electrically power machine that is associated with water.

Ensure that the power requirements of the machine are met. Low or under voltage may lead to premature failure of the burner motor.

### **IMPORTANT!**

Do not cut off the ground pin. The operator will be exposed to a shock hazard.

Keep electrical cords and connections dry at all times.

Use only #1 or #2 fuel oil with this burner.

**Although no accessories are supplied with this heater module, It is imperative that the correct gun be used for the correct application. Below are examples of what should be used and for what purpose.**

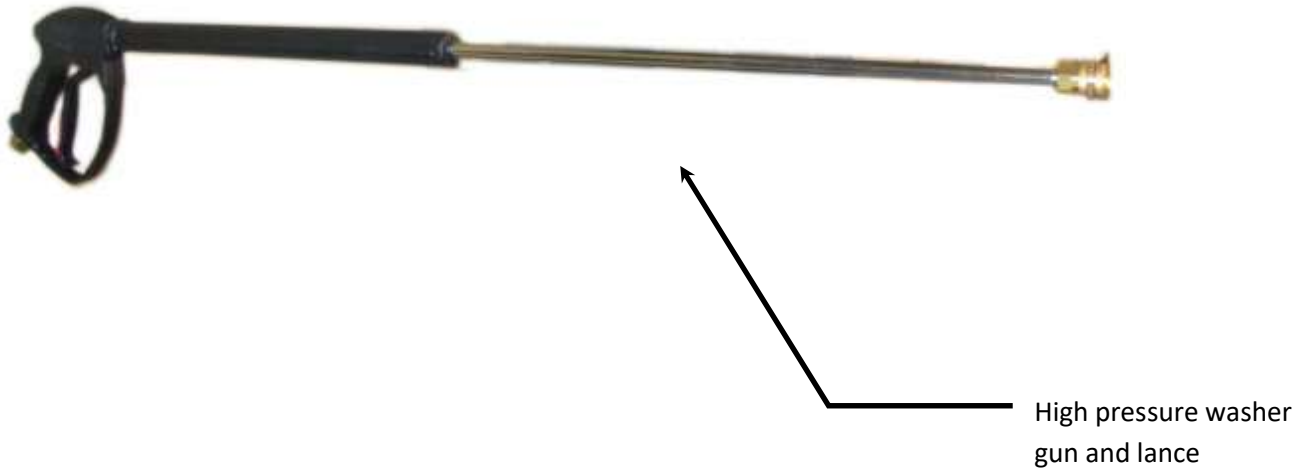

## **CONNECTING AND INSTALLATION INSTRUCTIONS**

### **Stationary Installations**

Ensure that any required plumbing, electrical, and exhaust venting work is done by authorized trade's people in accordance with local regulations.

Caution: If the heater module is left unused for extended periods in sub-zero temperature, a column of freezing air can build up in the venting system. If the building has a negative pressure condition, some of the freezing air will be drawn over the draft hood, spilling onto the heating coil causing water in the coil to freeze, which may eventually cause coil to rupture. Have installer ensure that correct draft conditions are maintained to prevent this. Or if the heater module is installed on a remote service vehicle steps need to be taken to ensure the heater module is properly winterized at all times when not in use.

### **Remote piping**

If you are installing permanent piping runs from your Dynablast unit to remote wash locations, use only Schedule 80 pipe and heavy duty fittings rated for the operating pressure of your pumping module or use pressure or steam rated reinforced flexible hose suitable for the operating pressure.

### **Relief Valve**

The units come complete with pressure relief valve fitted. The relief valve is extra protection against damage that could be caused by malfunctioning controls or excessive water pressure.

### **Protection from Freezing**

If your unit is likely to be exposed to freezing temperatures, it can be extensively damaged by water freezing inside the machine. Freezing can cause the heat exchanger coil to split. Freezing can cause pump heads to crack. Damage from equipment freeze up is not covered by warranty. The most dependable approach to cold weather protection for your machine is to not expose it to freezing temperatures. If you must risk freezing the unit, it should either have all of the water drained from the complete unit or the complete unit should be filled with a suitable antifreeze solution.

## **Burner Set up**

Plan your installation carefully before you begin. Determine how you are going to supply fuel (#1 or #2 fuel oil) and electricity (if applicable) to the unit. The fuel tank for the heater module needs to be located near enough to the module to ensure proper drawing conditions are met for the fuel pump. This module uses a 2 line fuel system (one feed line, one return line). Connect the feed line to the inlet connection of the fuel strainer (as shown below). Connect the return line (that will return fuel back to your fuel supply tank) Fuel line should be a minimum of 1/4" inside diameter, flexible hose. The maximum vertical high of the suction line is 6 ft, and a total length of 40 ft. no copper tubing should be used.

## Fuel hook up HV700FLS / HV900FLS

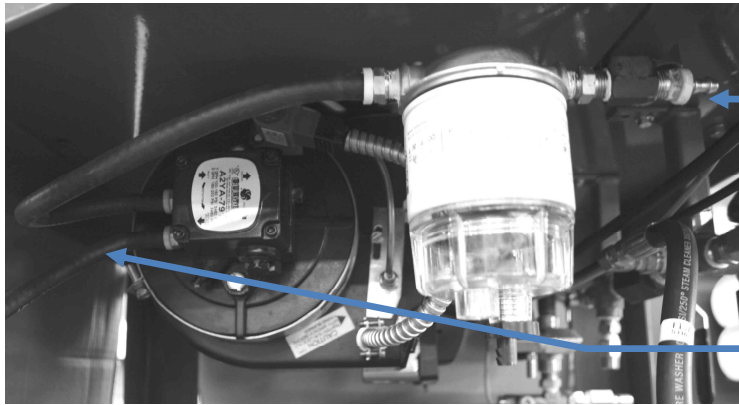

Supply line  
connection

Return line

If the heater module will be mounted in a remote service vehicle, it must be mounted to a ridged part of the frame to ensure adequate support. Keep in mind the heat exchanger coil is very heavy with a great deal of mass towards to top of the coil.

## Water connections for HV700FLS / HV900FLS

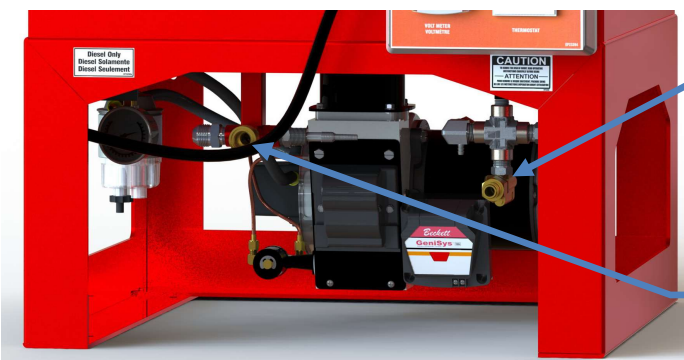

Cold water  
inlet

Hot water  
outlet

Connect the outlet of the high pressure pumping unit to the cold water inlet of the heater module

## Fuel supply:

The supply of fuel for the burner should be uninterrupted, or continuous. This burner uses a 2 fuel line system, (supply and return). The supply and return lines are to be as short and direct as possible limiting the vertical suction lift (also consider the fuel level of the tank will drop over time). We recommend the vertical lift not to be more than 8'. There is a fuel filter with a water separator. This should be inspected regularly and maintained. (refer to the maintenance schedule )

## OPERATING INSTRUCTIONS

***WARNING: IF YOU DO NOT FOLLOW THESE INSTRUCTIONS EXACTLY, A FIRE OR EXPLOSION MAY RESULT CAUSING PROPERTY DAMAGE, PERSONAL INJURY OR LOSS OF LIFE. DO NOT TAMPER WITH FACTORY INSTALLED CONTROLS.***

### BEFORE YOU TURN ON THE BURNER

#### Ensure the following;

- 1) You have an adequate supply of fresh water to feed your high pressure pump.
- 2) You have an adequate supply of #1 or #2 fuel oil.
- 3) Your electrical supply is adequate.
- 4) Your supply pump is properly hooked up.
- 5) Your trigger gun is hooked up, and you've selected the correct function on the control panel for the type of gun you will be using. (illustrated below)

### To operate high pressure hot water system

- a) Connect a high pressure hose, gun and lance to the high pressure side of the outlet of the heat exchanger.

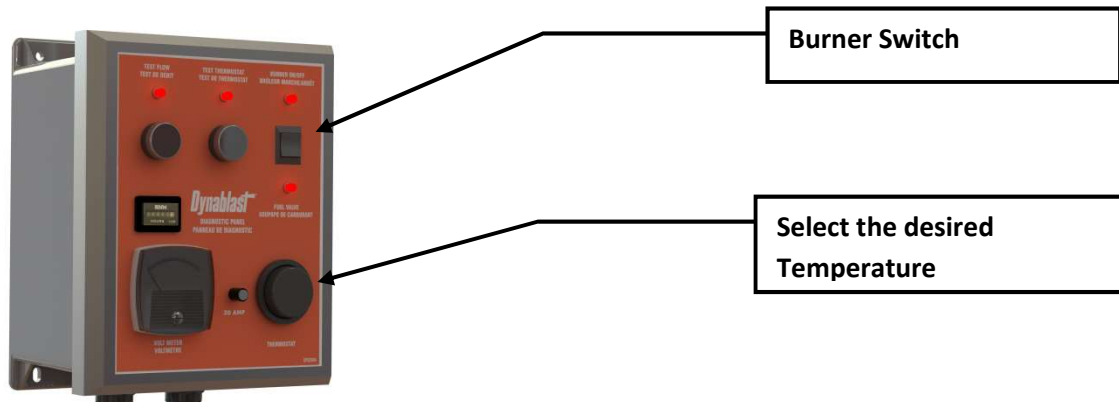

- b) Be sure water can flow to the heater coil before turning on burner switch. Start the pumping unit involved until a steady stream of water is flowing from the spray gun (holding the spray gun open). Turn burner switch to "ON" position. Burner will ignite and remain in operation as long as there is sufficient water flow to satisfy the flow switch and temperature limit control. To shut off main burner, turn burner switch to "OFF".

Holding the gun/wand with both hands, pull the trigger gun open and check for proper operation and then proceed with your cold water washing task.

## Shutdown Procedure

- Turn the burner control switch to the “OFF” position and continue to run water through the unit until the heater coil is completely cooled to inlet water temperature. This procedure reduces the tendency of scale to accumulate inside the heat exchanger coil.

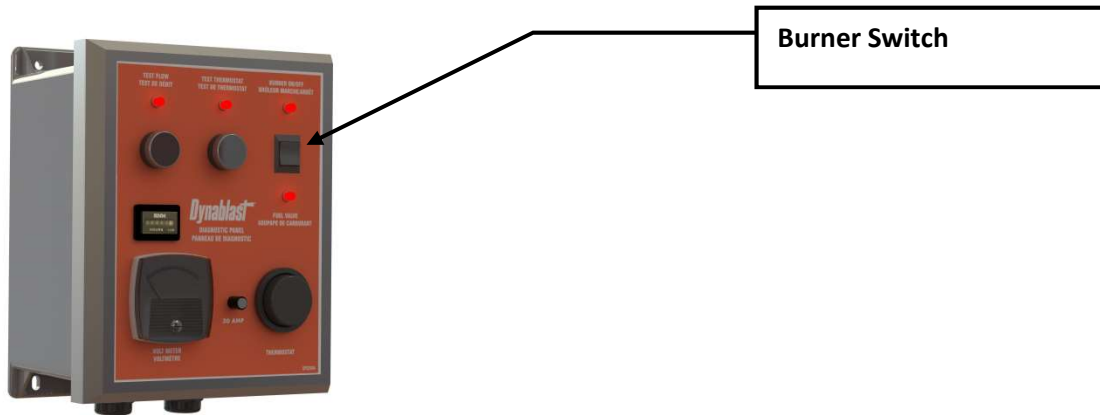

**After the high pressure pumping unit has been turned off. Pull the trigger of the gun to relieve any trapped high pressure.**

- Turn the burner control switch to the “OFF” position and continue to run water through the unit until the heater coil is completely cooled to inlet water temperature. This procedure reduces the tendency of scale to accumulate inside the heat exchanger coil.
- Disconnect the gun/wand from the outlet hose and drain the water from the gun/wand by holding the trigger gun open and pouring any water out backwards through the gun.

**Caution:** DO NOT attempt to start the burner when excess fuel has accumulated, or when the heat exchanger coil is full of vapors, or when the combustion chamber is hot.

 Vapor-Filled combustion chamber: Allow the unit to cool off and all vapors to dissipate before attempting an- other start

 Oil flooded combustion Chamber: Shut off the electrical power and the oil supply to the burner, then clear all accumulated oil before continuing

When changing nozzles, always cool down water coil then turn off the machine, release high pressure trapped inside, and latch the trigger lock on the gun. Always point the nozzle away from you during this process. Never point the nozzle towards any other persons or animals. Ensure the replacement nozzle is firmly secured in its position before you start washing.



## Maintenance

To remove any loose rust or scale which could become loose and clog the outlet nozzle or affect normal pump operation, flush the machine for about two minutes prior to using it for the first time and again if the machine has not been used for a few days. Flush the machine by removing the nozzle from the wand or by removing the complete gun/wand assembly from the output hose and then turning on the pumping module. (It is not necessary to operate the heater while you are flushing the unit.)

High pressure nozzle replacement interval: replace the high pressure nozzle whenever there is a noticeable drop in performance. Use the correct size orifice than matches the out flow rate and pressure of the pumping unit.

High pressure hose maintenance check: visually inspect high pressure hoses dally. Check for any sections of the hose that have signs of abrasion on the out sleeve. Ignoring this could lead to a hose rupture, or high pressure pin hole leak.

### Water Hardness and Scale Buildup

Units operated in areas with "hard" or high mineral content water supply are often prone to developing a scale buildup within the heat exchanger coil (similar to deposits seen in electric kettles used to heat "hard" water). The tendency for scale to accumulate can be minimized by completely cooling the coil after each use. Allow water to flow through the coil with the burner turned "OFF" until the coil has cooled to the temperature of the inlet water. When water conditions are such that scale buildup is inevitable, we recommend checking for visible accumulation of scale in the heater coil regularly. If there is any scale visible inside the pipe at the heat exchanger outlet, have the coil de-scaled by a qualified service technician. Refer to the de-scaling procedure outlined later in the appendix.

Check for scale buildup in the coil. Remove the hose from the heat exchanger outlet and look for any visible scale accumulation. Excessive scale build up will reduce the heat transfer from the burner to the water, thus reducing the effectiveness of the heater module.

### DESCALING THE COIL

**WARNING:** *Coil de-scaling using acid should only be done by qualified personnel.*

The best way to acidize the coil is with a circulating pump capable of handling acids:

1. Fill a plastic container with a suitable acid diluted with water to the desired strength.
2. Connect the discharge from the circulating pump to the hot water outlet on the water heater with a suitable hose. Connect the inlet of the circulating pump to the acid container with the suction hose. Disconnect the water heater inlet hose from the pump module and use it as a return hose to the acid container. Start the pump, circulating the acid solution through the coil and back into the acid container, As the acid dissolves the scale it becomes neutralized, so about every five minutes add more acid to the container until all the scale has been removed from the coil. Flush out coil thoroughly with water after de-scaling.

If no circulating pump is available, another good method can be used:

1. Remove high limit control and piping from coil outlet. Install a standpipe on the outlet of the coil. Disconnect the water heater inlet hose from the pump module and run to a drain or suitable container.
2. Remove cap from standpipe and pour in about 1/2 gallon of acid diluted 50/50 with water. Screw cap back on stand pipe immediately. **Caution:** Do not stand directly over chamber when pouring, as acid may blow back upon contact with scale. After ten minutes, pour more acid into chamber. Repeat same procedure until coil is free of scale. Flush out coil thoroughly with water after cleaning. **Caution:** Never allow acid to remain in coil for long periods of time.

## **Outlet Accessories**

Most pressure wash applications are made easier to perform by using the outlet device that best suits the task at hand. The list below summarizes the most common types of outlet devices - consult with your Dynablast dealer for more information.

### **Standard Pressure Wash Nozzles**

The standard pressure wash nozzle that is normally supplied with your Dynablast unit has an orifice sized for the output specifications of your unit. However, there is a wide variety of spray angle patterns available for most orifice sizes. Your Dynablast dealer usually stocks angles ranging from 0° to 40° for common orifice sizes and your dealer can advise you which pattern will work best for your application.

### **Specialty Nozzles**

Consult your dealer for demonstrations of rotary nozzles (intensifiers), foam lances, wet sandblasting attachments, variable spray angle nozzles, water brooms and sewer and pipe cleaning nozzles.

### **Wands**

Wands are available in a wide variety of lengths. Short wands simplify access in confined areas; long wands reach into those awkward spots and minimize ladder movement. Your Dynablast dealer usually stocks a complete range of sizes.

### **Pressure gauge fuel line**

With respect to the pressure gauge fuel line, high pressure fuel line must be used for fuel line going from the burner to the fuel pressure gauge (high pressure side).

Must be rated minimum 200 psi

## Specifications

	MODEL	HV700FLS	HV900FLS
SPECIFICATION	MAX PRESSURE (psi)	3500	3500
	HEAT ENERGY (btu)	700,000	900,000
	FUEL TYPE	no 1 OR no 2 FUEL OIL	no 1 OR no 2 FUEL OIL
	BURNER VOLTAGE	120V / 4.8 AMP	120V / 4.8 AMP
BURNER	BRAND	WAYNE	BECKETT
	MODEL NUMBER	EH	CF800
	FIRING RATE (GPH)	5.03	5.81
	STACK DIAMETER (IN)	10"	12"
	FUEL PRESSURE (PSI)	125	135
	FUEL NOZZLE	4.5 80°B	5.0 80°B
SAFETY COMPONENTS	THERMOSTAT	STANDARD	STANDARD
	FLOW SWITCH	STANDARD	STANDARD
	HIGH TEMPERATURE LIMIT PROTECTOR	STANDARD	STANDARD
	HIGH PRESSURE BLOW OFF VALVE	STANDARD	STANDARD
FEATURES	PORTABLE	NO	NO
	FINISH	POLYESTER POWDER	POLYESTER POWDER
	DIMENSIONS (LxWxH) (IN)	26.5 x 26.5 x 58	26.5 x 26.5 x 64
	WEIGHT (LBS)	790	890
	COIL	3/4" SCH 80 PIPE	3/4" SCH 80 PIPE

### Initial factory settings:

**HV700FLS Air band ½ open**

**HV90FLS Air band 5 Air shutter 9**

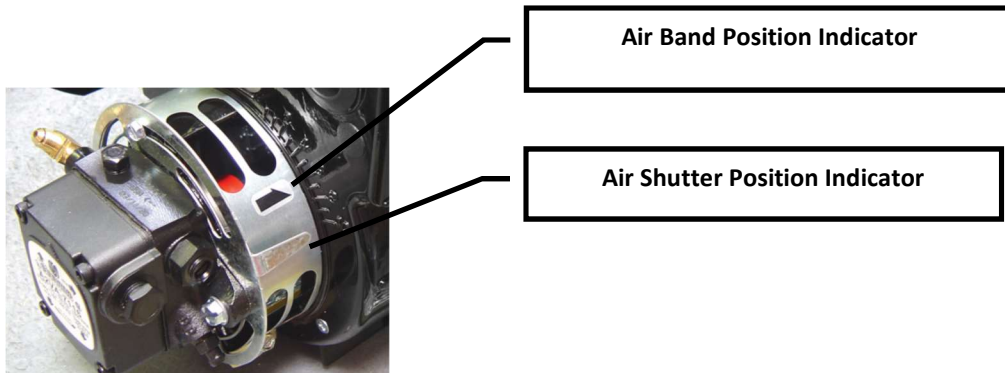

## Troubleshooting Guide

**WARNING: POTENTIAL FOR FIRE, SMOKE AND ASPHYXIATION HAZARDS**

Repairs or adjustments to the burner must **ONLY** be carried out by a professional, qualified oil fired burner Technician. Incorrect installation, adjustment or misuse of this burner could result in death, severe personal injury, or substantial property damage.

TROUBLE	POSSIBLE CAUSE	REMEDY
<b>Burner will not ignite</b>	No fuel or contaminated fuel	Fill fuel tank and check fuel filter for water and other contaminants.
	Primary control soft lockout (Refer to guide below)	Reset primary control (hold for 15sec and release) See controller image below
	Primary control hard lockout (Refer to guide below)	Reset primary control (hold for 30+sec and release) See controller image below
	Faulty thermostat	Replace
	Plugged oil nozzle	Replace (do not clean)
	Electrodes out of alignment	Adjust.
	Electrodes insulator failure	Check for breaks, cracks, or sparks trails-Replace.
	Water flow switch not closing	Adjust, repair or replace.
	Fuel solenoid valve not opening	Clean, repair or replace.
	Weak transformer	Clean and check transformer terminals. Replace if necessary. Check for spark.
	Faulty burner oil pump	Adjust or replace
<b>Burner will ignite and run but flame is lost shortly thereafter</b>	Air trapped in fuel system	Bleed fuel system
	Thermostat set too low	Adjust thermostat
	Faulty thermostat	Replace
	Faulty flow switch/flow switch probe	Replace
	Faulty Primary control (Refer to guide below)	Replace
<b>Surface of Cabinet getting hot</b>	Tear in insulation around coil	Repair or replace
	Gap between coil insulation and top cap	Remove cap and add or adjust insulation to remove gap
	Coil bottom insulation disturbed	Remove coil repair or replace bottom insulation
	Misaligned burner flame tube	Inspect for visual damage to flame tube flange assembly. Adjust, repair or replace flame tube assemblies.
<b>Water leak</b>	Loose fitting(s)	Tighten fitting(s)

	Frozen coil	Repair or Replace.
	Broken fitting(s)	Replace.
	Severe condensation	Check insulation on bottom and around coil. Repair any tears or gaps in insulation.
<b>Burner runs but does not run smooth</b>	Air band open too much or too little	Adjust air band
	Fuel filter/fuel connections loose	Tighten or repair
	Fuel nozzle clogged	Replace fuel nozzle
	Air in fuel system	Bleed Fuel system
<b>Unit Smokes</b>	Improper fuel	Use No. 1 or No. 2 Fuel Oil
	Combustion air insufficient	Adjust air band
	Fuel nozzle interior loose	Replace nozzle
	Electrodes misaligned	Adjust electrodes
	Excessive soot build up on coil	Clean coil
	Fuel filter clogged	Clean fuel filter/replace
	Improper fuel pressure	Fix visible leaks. Check for clogged fuel lines. Service or replace fuel filter and/or fuel pump.
<b>Water temperature lower than normal</b>	Thermostat set too low	Adjust thermostat
	Water inlet temperature lower than normal (50°F)	Not applicable
	Water flow rate higher than normal	Adjust flow rate to machine specifications
	Coil limed up	Descale coil
	Improper combustion	Readjust burner
	Thermostat malfunction	Replace
<b>Blowing Fuses</b>	Dead short	Check all wires and connections
	Wrong fuse	Replace with proper rated fuse
	Clogged or seized fuel pump	Repair or Replace
	Burner drawing too much current	Replace burner or repair burner components
	Motor seized	Replace burner motor
	Broken blower wheel	Replace blower wheel
<b>Burner continues to run after washing is stopped</b>	Faulty flow switch/flow switch probe	Replace flow switch/flow switch probe

**NOTE: Use replacement insulation of manufacturer specifications.**

Beckett CF800 / Wayne EH Oil Burner with integrated Controller



Refer to Beckett & Wayne owner's manual.

Getting to know your 120V primary control



**Note: Ensure 220R 2W 5% CF resistor is install on Thermostat Terminals to remove potential electrical interference.**

**Table 2 - Reset Button Operation**

If the burner is in the below state:	Pushing the reset button will:		
	Button Click (press < 1 second)	Button Hold (press > 1 second)	Button Hold (press 15+ seconds)
Lockout	Reset from Soft Lockout		Reset from Restricted (Hard) Lockout
Valve-on Delay, Trial for Ignition, Ignition Carryover	Go to Pump Prime (see "Priming the Pump" above)	Disable the Burner: Any time the burner is running, press and hold the reset button to disable the burner. The burner will remain off as long as the button is held.	Enables Pump Priming: After the reset button has been held for 15 seconds, the button can then be clicked during the next ignition sequence to enter Pump Prime mode.
Run (igniter is shut off)	No action		
Motor-Off Delay, Standby	No action		
Pump Prime	No action	Exit Pump Prime mode and return to Standby	

**Table 3 - Status Lights**

Light Color	On Continuously	Flashing
Red	Restricted (Hard) Lockout	Soft Lockout
Green	Flame Sensed during normal operation (Could be stray light during standby)	Recycle
Yellow	Control is in Pump Prime mode <b>or</b> Reset button currently held for 15+ seconds.	N/A

Refer to Beckett & Wayne owner's manual.

## Warranty Policy

This product is warranted to be free from defects in materials and workmanship under normal use and service, for a period of one year from the date of purchase, unless stated otherwise below, when operated and maintained in accordance with the Maintenance and Operation Instructions supplied with the unit. The warranty does not cover misuse or negligence.

This warranty is extended only to the original purchaser. Hoses, spray guns, wands and other accessories are warranted for 90 days. Warranty is void if repairs are attempted by anyone other than an Authorized Service Centre.

If a difficulty develops with the product, you should contact the nearest Authorized Repair Centre or DYNABLAST INC. office. Only these locations are authorized to make repairs to the product or replacement of defective parts, which will be done at no charge within a reasonable time after receipt of the product. Units or parts should be returned at the customer's expense to the nearest DYNABLAST location or Authorized Service Centre. Pack unit in a strong carton and pad tightly to avoid damage. Damage in transit is not covered by warranty. Include original purchase receipt with any claim (but keep a copy for your files).

DYNABLAST INC. liability under warranty is limited to repair of the product and/or replacement of parts and is given to the purchaser in lieu of all other remedies including incidental and collateral charges. There are no expressed warranties other than those specified herein.

<b>SPECIAL WARRANTIES</b>	<b>WARRANTY PERIOD</b>
Fabricated Components	1 year parts, 1 year labour
Burner, Transformer, Control Switch, Safety Switch Pressure and Flow Switch	1 year parts and labour
Schedule 80 Heating Coil Limited Warranty *(see below)	3 year parts, 1 year labour
Schedule 40 Heating Coil	2 year parts, 1 year labour

*We must receive the coil serial number section of the coil to substantiate the warranty claim.*

*We will not replace coils under warranty if the coils have been subjected to misuse such as:*

**1. Freezing 2. Lime Deposit 3. Other foreign material deposit 4. Shock or Vibration**

Any replacement during the warranty period will have a warranty of one (1) year, or the balance of the original warranty, whichever is greater.

Contact your dealer for sales and service support. For your nearest dealer, contact Dynablast Inc. Mississauga, Ontario, Canada at 1-888-881-6667



## How to determine Faulty Primary control, Cad Cell or Safety Devices:

**NOTE:** All service work performed on your burner should be completed by a trained technician.

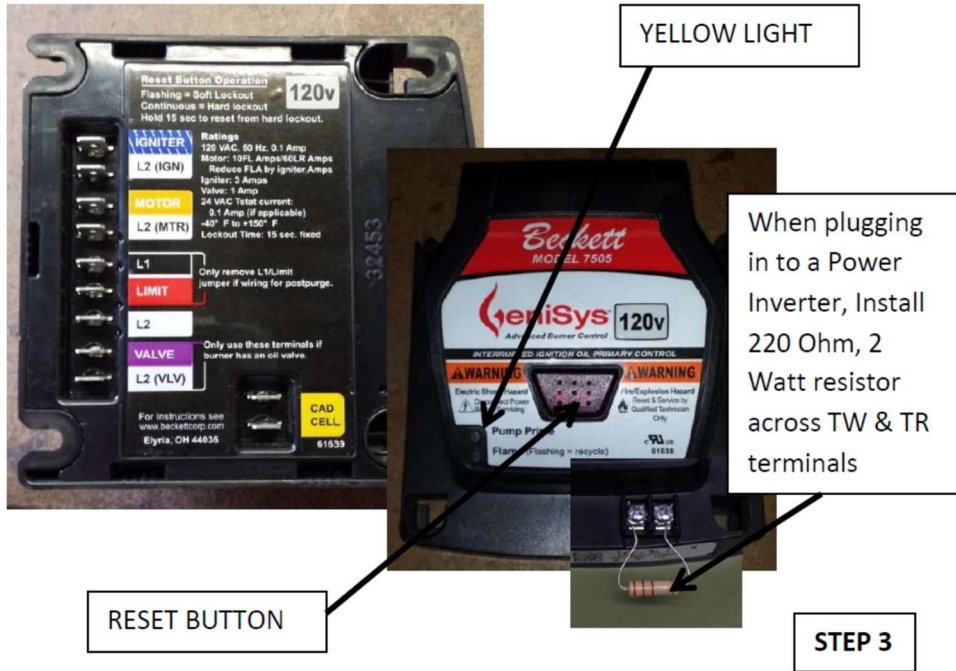

### STEP 1

L1/L2– Should measure 102-132VAC when power is on and switches are on.

IF L1/L2 does not read above voltage check the following:

- Fuse may be blown/loose or not installed (if circuit breaker is installed make sure reset is pushed in)
- Burner Switch may not be turned on or defective
- Power supply breaker turned off

### RESET BUTTON

### STEP 2

LIMIT/L2 – Should measure 102-132VAC when unit is on and all limits are operating correctly.

If LIMIT does not read above voltage check the following:

- Ensure limits are functioning. Flow switch and thermostat can be bypassed using momentary pushbuttons on the diagnostic control panel (if installed).
- All other limits must be bypassed out of circuit one at a time to determine which is faulty.

COMPONENT	PART #
CONTRACTOR TOOL	HW52082U
CAD CELL	HW7006U
PRIMARY CONTROL	HWHE7505A000U

### STEP 3

Determining Bad Cad Cell:

**Using the Contractor tool:**  
Look at display to view cad cell resistance reading during run state. A reading of 1600 ohms or more will determine a limited functioning cad cell. If ohm reading is 1600 ohms or more clean cell and check again. Replace cad cell if value does not drop.

**Without a Contractor tool:**  
During burner run state press the reset button. Yellow LED will flash

- 1 flash = 0-400 ohms (Normal)
- 2 flashes = 400-800 ohms (acceptable-check cad cell contacts and/or clean cad cell)
- 3 flashes = 800-1600 ohms (refer to 2 flashes)
- 4 flashes = 1600-Lockout (Limited – clean or replace cad cell).

### STEP 4

If L1/L2 and LIMIT/L2 terminals have proper voltage and cad cell is determined to be functioning; check voltage across the following terminals:

- IGNITER/L2(IGN)
- MOTOR/L2(MTR)
- VALVE/L2(VLV)

ALL SHOULD READ 102-132VAC.

If one or more do not read above voltage replace Primary control.

If correct voltages are present check burner components and replace if necessary.

For igniter ensure electrodes are aligned with transformer contacts, properly gapped and clean. [Refer to page 6 (figure 1) of Wayne EH Manual for electrode gap dimension]

**Parts Breakdown HV700FLS**

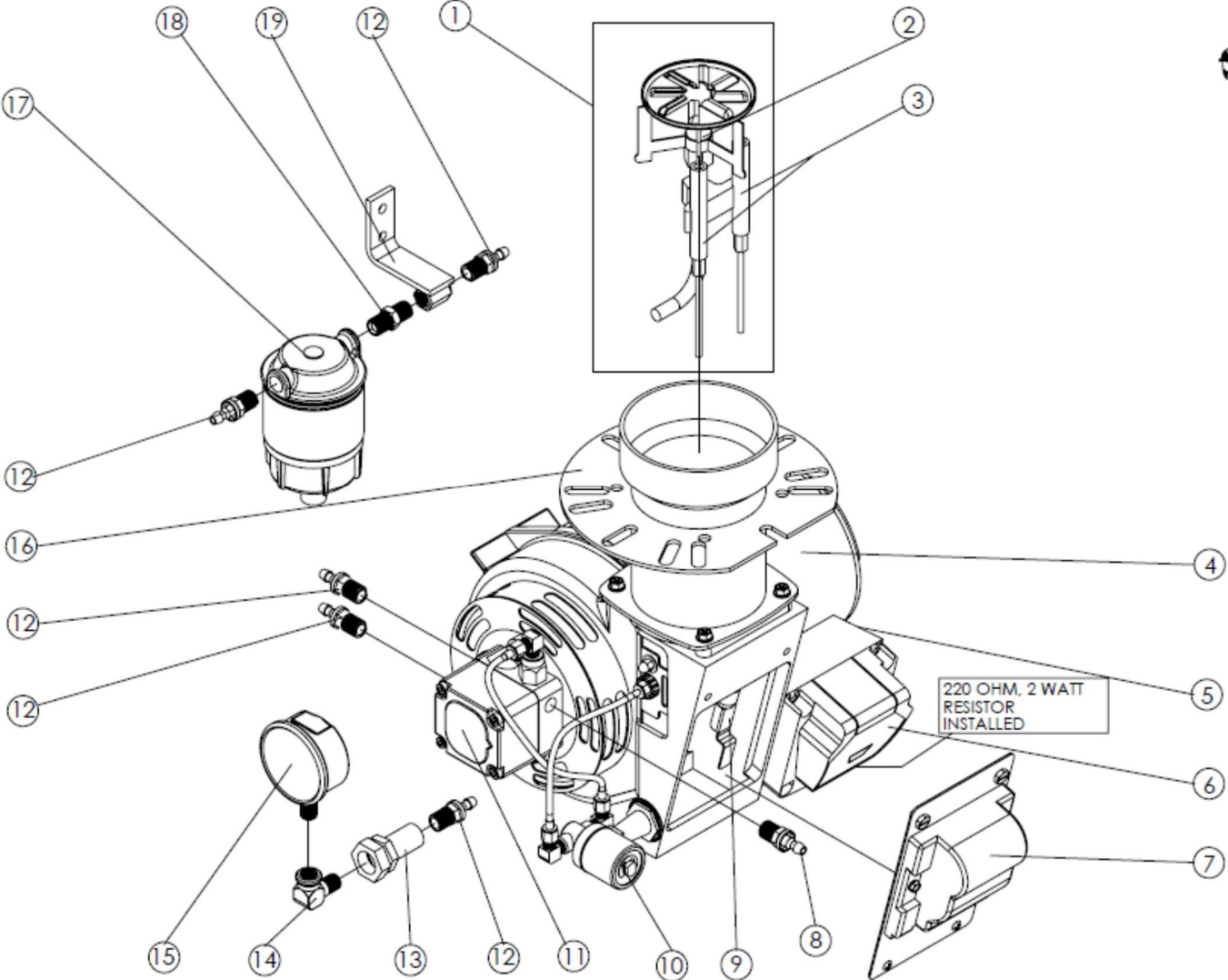

**Parts Breakdown HV700FLS**

<b>BURNER ASSEMBLY</b>			
<b>ITEM NUMBER</b>	<b>PART NUMBER</b>	<b>DESCRIPTION</b>	<b>QUANTITY</b>
1	HWHE31761-082	GUN ASSEMBLY	1
2	HW4.580B	FUEL NOZZLE	1
3	HWHE13286	ELECTRODE KIT	1
4	HWHE21126	BURNER MOTOR	1
5	HWELBC52171-K	4X4X2 STEEL JUNCTION BOX	1
6	HWHER8184G1031	120V PRIMARY CONTROL	1
7	HWHE101295-SERE	WAYNE IGNITER	1
7	HWHE51827U	BECKETT IGNITER	1
8	HWFI125-4B	BARB FITTING	1
9	HW7006U	CAD CELL	1
10	HWHE100610-001	FUEL SOLINOID	1
11	HWHE14375	FUEL PUMP	1
12	HWFI725-4B	BARB FITTING	5
13	HWFID1495B-L	BRASS BULK HEAD FITTING	1
14	HWFI116-B	BRASS ELBOW	1
15	HWHEPFQ807	FUEL PRESSURE GAUGE	1
16	HWHE12484	BURNER GASKET	2
17	HWHE140R	FUEL FILTER	1
18	HWFIS1022-B	HEX NIPPLE	1
19	HWEP24409	FUEL FILTER BRACKET	1

**Parts Breakdown HV900FLS**

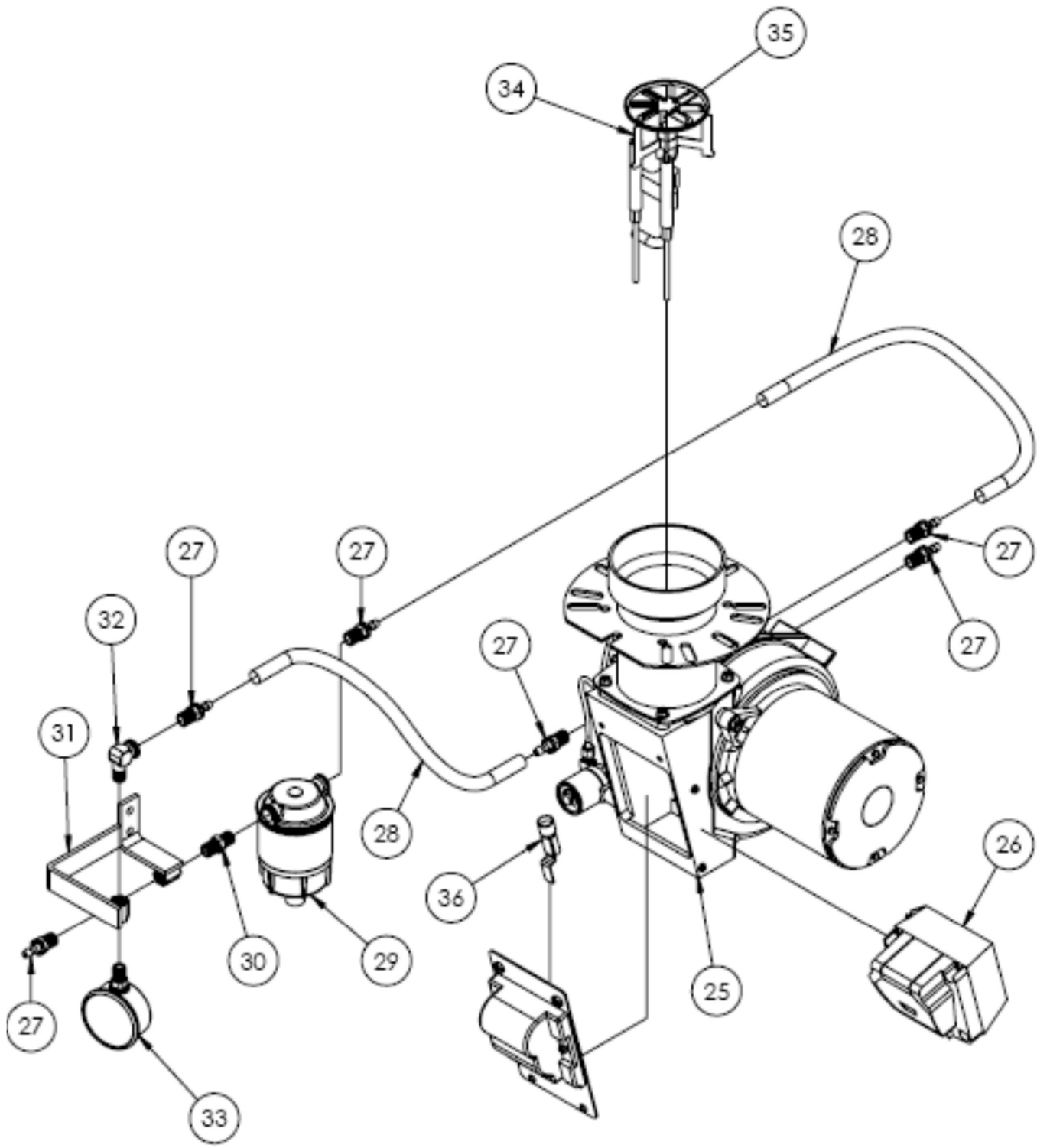

**Parts Breakdown HV900FLS**

<b>ITEM NO.</b>	<b>PART NUMBER</b>	<b>DESCRIPTION</b>	<b>QTY.</b>
25	HWHEEPCF800 (EP1301)	900 BECKETT BURNER	1
26	HWHE7505A0000U	PRIMARY CONTROL	1
27	HWFI1725-4B	1/4 PUSH X 1/4MP ADAPTOR	6
28	HWEP80057	1/4 ID FUEL LINE	18"
29	HWFIA-25A	RACOR FUEL FILTER	1
30	HWFIS1022-B	1/4 X 1/4 HEX NIPPLE	1
31	HWEP24456	FUEL FILTER BRACKET	1
32	HWFI116-B-PH	1/4" x 1/4" 90 DEG ELBOW	1
33	HWHEPFQ807	0-300 PSI GAUGE	1
34	HWHE51345	ELECTRODE ASSEMBLY FOR EP1301	2
35	HW5.080B	FUEL NOZZLE 5.0 GPH 80B	1
36	HWHE7006U	CAD CELL	1

**Parts Breakdown HV700FLS / HV900FLS**

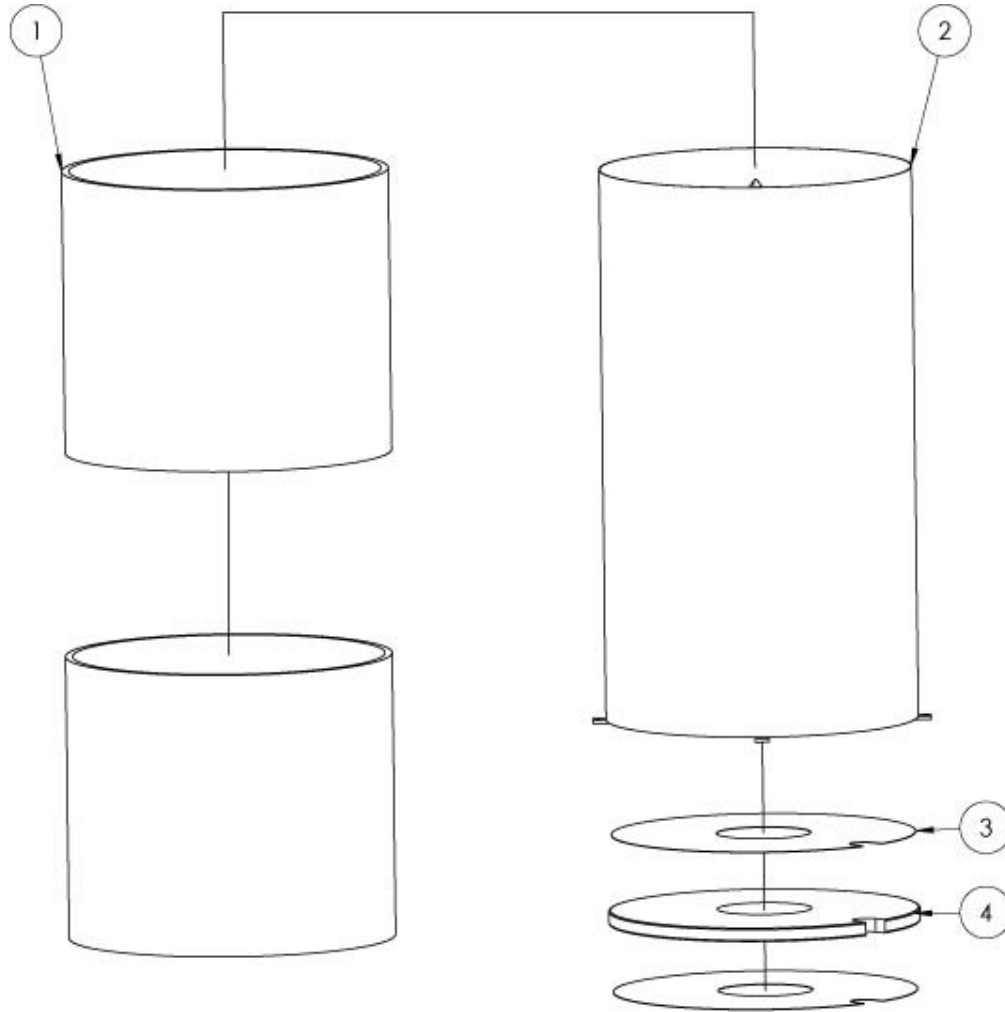

Ref No	Part Number	Description	Quantity
1	HWHEQ80753	82" X 24" X 1" 607 BLKT	2
2	HW40209	700 Coil	1
	HW40210	900 Coil	1
3	HWEP27167	Bottom Steel Ring	2
4	HWHEQ80752	Bottom Insulation Ring	1

**HW40209KIT INSULATION KIT REQUIRED WITH COIL 700 or 900 REPLACEMENT**

**Parts Breakdown HV700FLS / HV900FLS Inlet**

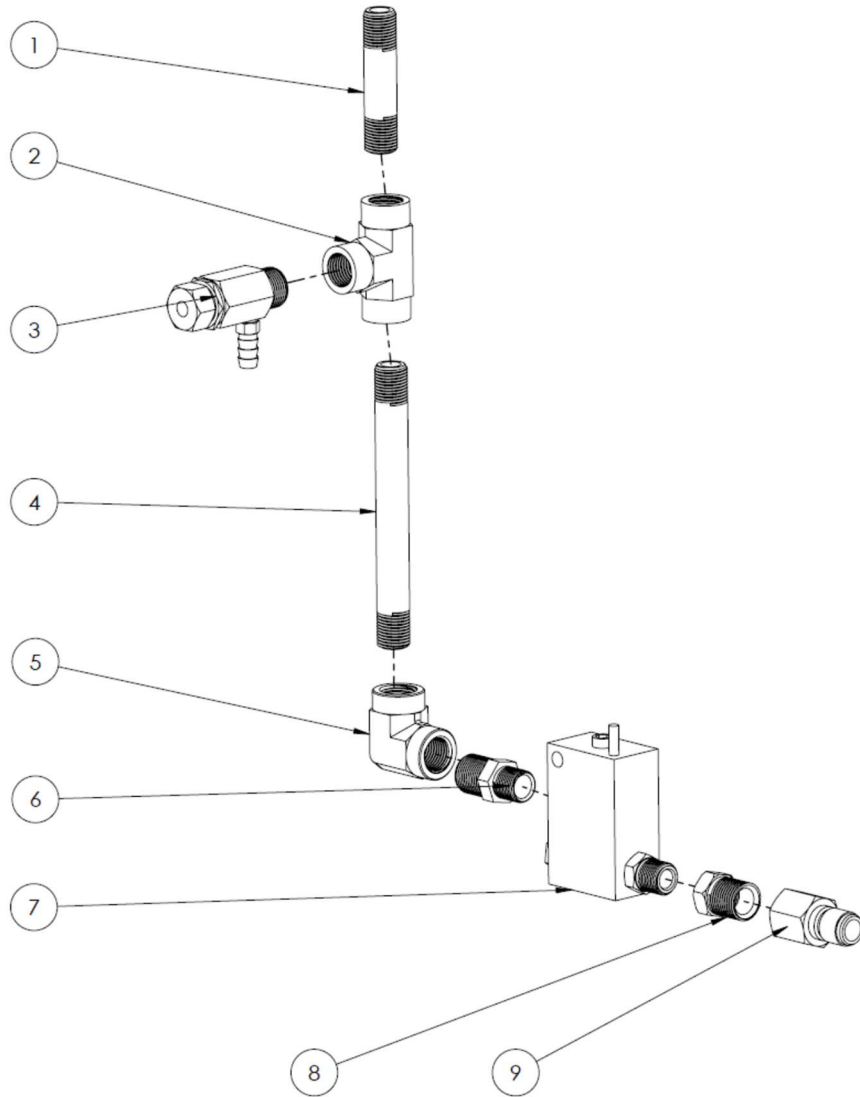

Ref No.	Part Number	Description	Quantity
1	HWFIMP113-D41/2H	1/2" X 4.5" NIPPLE	1
2	HWFIS1001-D	1/2" TEE	1
3	GP100984	12 GPM Relief Valve	1
4	HWFIMP113-D6H	1/2" X 6" Steel Nipple	1
5	HWFIS1000-D	1/2"F X 1/2"F Steel Elbow	1
6	HWFIS1022-DC	1/2"F X 3/8" MALE NIPPLE	1
7	GP103011	FLOW SWITCH	1
8	HWFIS1010-DC	3/8"F X 1/2"M Steel Bushing	1
9	HWEF22217FP	QUICK COUPLER	1

**Parts Breakdown HV700FLS / HV900FLS outlet**

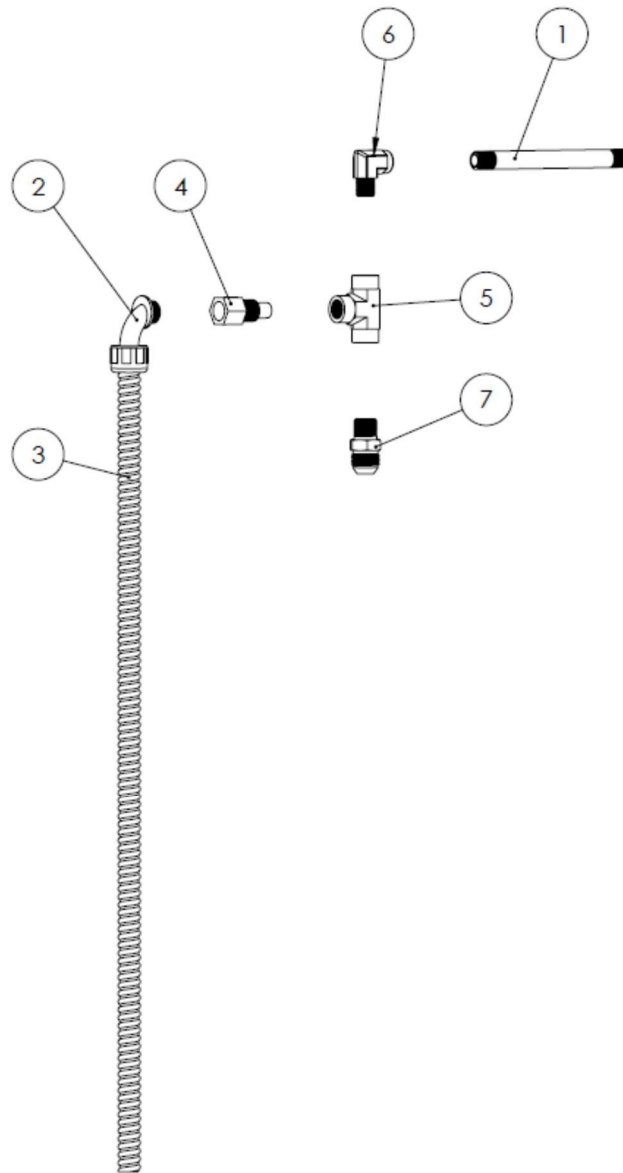

Ref No	Part Number	Description	Quantity
1	HWFIMP113-D4H	4" x 1/2" Nipple (Length May Vary)	1
2	HWELHFC1290	1/2" 90 Degree Liquid Tight Fitting	1
3	HWELHF2-12	1/2" Liquid Tight Conduit Hose	3ft
4	HWT44110NL	High Limit 100C/230F	1
5	HWFIS1001-D	1/2" FP Tee	1
6	HWFIS1015-C	1/2" F x 1/2" M Elbow	1
7	HWFI5348-12D	JIC Fitting	1



**Parts Breakdown HV700FLS / HV900FLS**

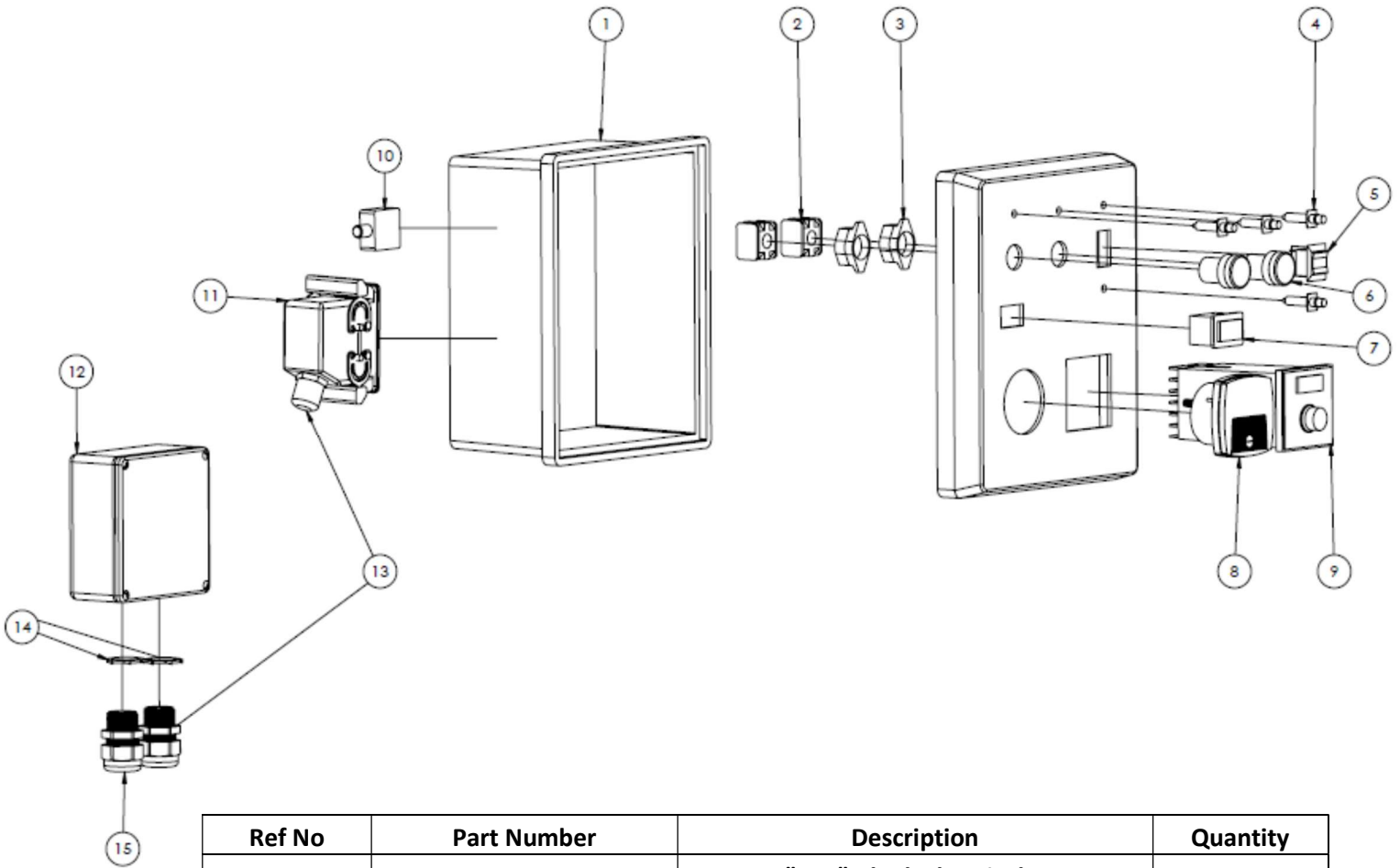

Ref No	Part Number	Description	Quantity
1	HWELVJ1008	10" X 8" Blank Electrical Box	1
2	Included with part # 6	Contact Block	2
3	Included with part # 6	Push Button Housing	2
4	HWELKS3250	Pilot Light	4
5	HWEL2504-11E	Burner Switch	1
6	HWELPBMC	Push Button	2
7	HWELGO-891-204	Hour Meter	1
8	HWEL18235	Volt Meter	1
9	HWMC7211	Thermostat	1
10	HWELW58XB1A4A-15	15 Amp Circuit Breaker	1
11	HWELDISC-10	10 Pin Quick Connect	1
12	HWELJB552	5" X 5" Blank Electrical Box	1
13	HWELF8552	PG Strain Relief	2
14	HWEL1706	3/4" Conduit Locknut	2
15	HWEL3234	1/2" Strain Relief	1

# HV700FLS / HV900FLS W GP103011

