

OPERATING INSTRUCTIONS MANUAL

(Please retain for future reference)

For

FVNP-400RC INDIRECT FIRED SPACE HEATERS

CERTIFIED FOR USE IN CANADA AND U.S.A.

As per Standard ANSI Z83.7/CSA 21.4 2000 Gas Fired Construction Heaters / Unattended Type.



Issued: September, 2016



FLAGRO INDUSTRIES LIMITED
ST. CATHARINES, ONTARIO
CANADA

GENERAL HAZARD WARNING:

FAILURE TO COMPLY WITH THE PRECAUTIONS AND INSTRUCTIONS PROVIDED WITH THIS HEATER, CAN RESULT IN DEATH, SERIOUS BODILY INJURY AND PROPERTY LOSS OR DAMAGE FROM HAZARDS OF FIRE, EXPLOSION, BURN, ASPHYXIATION, CARBON MONOXIDE POISONING, AND/OR ELECTRICAL SHOCK.

ONLY PERSONS WHO CAN UNDERSTAND AND FOLLOW THE INSTRUCTIONS SHOULD USE OR SERVICE THIS HEATER.

IF YOU NEED ASSISTANCE OR HEATER INFORMATION SUCH AS AN INSTRUCTIONS MANUAL, LABELS, ETC. CONTACT THE MANUFACTURER.

WARNING:

FIRE, BURN, INHALATION, AND EXPLOSION HAZARD. KEEP SOLID COMBUSTIBLES, SUCH AS BUILDING MATERIALS, PAPER OR CARDBOARD, A SAFE DISTANCE AWAY FROM THE HEATER AS RECOMMENDED BY THE INSTRUCTIONS. NEVER USE THE HEATER IN SPACES WHICH DO OR MAY CONTAIN VOLATILE OR AIRBORNE COMBUSTIBLES, OR PRODUCTS SUCH AS GASOLINE, SOLVENTS, PAINT THINNER, DUST PARTICLES OR UNKNOWN CHEMICALS.

WARNING:

NOT FOR HOME OR RECREATIONAL VEHICLE USE.

WARNING:

INTENDED USE IS PRIMARILY THE TEMPORARY HEATING OF BUILDINGS UNDER CONSTRUCTION, ALTERATION, REPAIR OR EMERGENCIES ONLY.

This heater is designed and approved for use as a construction heater under Standard ANSI Z83.7/ CGA 2.14. 2000.

We cannot anticipate every use which may be made of our heaters. CHECK WITH YOU LOCAL FIRE SAFETY AUTHORITY IF YOU HAVE QUESTIONS ABOUT APPLICATIONS.

Other standards govern the use of fuel gases and heat producing products in specific applications. Your local authority can advise you about these.

SPECIFICATIONS

Model	FVNP-400RC
Input	390,000 btuh
Fuel	Propane / Natural Gas
Manifold Pressure	1.5" W.C. Propane 2.0" W.C. NG
Maximum Inlet Pressure	13.0" W.C. Propane 10.0" W.C. NG
Electrical.....	120V 15 AMP
Ignition	Direct Spark Ignition
.....	Thermostat Control
Air Circulation	3500 cfm
Fuel Consumption	18.5 lbs/hr Propane 380 cfh NG
Approved	cETLus listed

INSTALLATION:

The installation of this heater for use with natural gas shall conform with local codes or, in the absence of codes, with the National Fuel Gas Code ANSI Z233.1/NFPA 54 and the Natural Gas and Propane Installation Code, CSA B149.1-00. This heater must be installed by a qualified gas technician, following local codes published by the authority having jurisdiction. All installations performed in the state of Massachusetts must be completed by a qualified plumber and gas fitter of the State of Massachusetts.

The installation of this heater for use with propane tank or cylinder shall conform with Local codes or, in the absence of local codes, with the Standard for the Storage and Handling of Liquefied Petroleum Gases, ANSI Z233/NFPA 54 and the Natural Gas and Propane Installation Code, CSA B149.

This heater must be located at least 10ft (3m) from any propane gas cylinder. This heater shall not be directed toward any propane gas container within 20ft (6m).

CLEARANCE TO COMBUSTIBLES:

<u>TOP</u>	<u>FRONT</u>	<u>SIDES</u>	<u>REAR</u>	<u>FLUE PIPE</u>
3 ft	10 ft	3 ft	3 ft	3 ft

ELECTRICAL:

WARNING

Electrical Grounding Instructions

This appliance is equipped with a three-prong (grounding) plug for your protection against shock hazard and should be plugged directly into a properly grounded three-prong receptacle.

115v supply must be available. Please note that the heater requires 15 amps for proper operation. Ensure appropriate gauge extension cord is used.

- 12/3 AWG at 50 Feet
- 10/3 AWG at 100 Feet

CONNECTING THE CYLINDER

If cylinders are used to supply the heater, no cylinders smaller than 100lb capacity shall be used. These cylinders must supply a vapor withdrawal only.

1. All cylinder connections must be made using a wrench to tighten the POL fitting.
2. Be sure that the cylinder valve is in the closed position when connection or disconnecting the cylinder.
3. A soap and water solution must be applied to all connections in order to leak check the system.

The gas must be turned off at the propane supply cylinder(s) when the heater is not in use. When the heater is to be stored indoors, the connection between the propane supply cylinder(s) and the heater must be disconnected and the cylinders removed from the heater and stored in accordance with Standard for the Storage and Handling of Liquefied Petroleum Gases, ANSI/NFPA 58 and CSA B149.1, Natural Gas and Propane Installation Code.

PIPING: This heater must be installed by a qualified gas technician following local codes published by the authority having jurisdiction. Sizing of supply piping must be determined using the length of pipe run as well as total btuh rating of the appliance(s). Appropriate piping tables must be used to determine size of supply piping dependant on the length of run from source.

PRESSURES:	MAXIMUM INLET PRESSURES:	LP: 13.0 IN. WC.
		NG: 10.0 IN. WC.
	MINIMUM INLET PRESSURES:	LP: 8.0 IN. WC.
		NG: 4.0 IN. WC.

This heater must be supplied by pressures indicated on the approval label. Over pressure may cause controls to fail. DO NOT supply this unit with more than ½ psig (14.0 in. W.C.)

Note: A second stage regulator must be installed if the supply pressure exceeds ½ psig.

FUEL: This heater is a dual fuel heater and operates on propane & natural gas. The manifold pressures are listed on the approval label.

You do not need to change any of the burner components; you just however, make sure the fuel selector valve is in the proper fuel position.

HOSES: All hoses used to connect this heater of fuel supply must be Type 1 approved propane / natural gas hose assemblies.

POWER SUPPLY INDICATOR LIGHT/VOLT METER:

The power supply indicator light will help detect any faulty power supplied to the heater such as; grounding issues, reverse polarity or missing/poor connections

Warning Light Indications

Green Light Meets Power Requirements

Solid Red Light..... Reverse Polarity

Solid Red & Green Light... Ground Issue

Volt Meter - Measures your voltage supply to the heater



ATTENTION: IF SOLID RED & GREEN IS INDICATED, MAKE CORRECTIONS TO POWER SUPPLY BEFORE TURNING HEATER ON. FAILURE TO DO SO WILL VOID ANY WARRANTY.

This heater is design to attach a return ducting system, see information below.

OUTLET DUCTING:

Hitex heater duct with a minimum temperature handling of 300 deg F. including wire reinforcement to prevent collapsing. Heater is designed for use with 2 x 12" diameter or 1 x 16" ducts equipped with pin lock/Cuff & Buckle couplings (FV-HD12 or FV-HDG16x25).

Install ducting to outlet on the heater using pin-locks provided on collar of ducting. Ducting should be inspected periodically for tearing and/or wear marks. Ducting should be stored in a dry area when not in use

INLET DUCTING: Ventflex duct must be used on the 16" return air. The heater is designed for 16" inlet diameter ducting. P/N FV-HDV16

FLUE PIPE:

Flue pipe connection must terminate with a vertical run at least 2 ft long. Horizontal runs should have a rise ratio of 1 in 10 away from the heater. The chimney should have a 0.2" W.C. draft to ensure safe operation of the unit.

The vent outlet on the heater is 6" diameter. Certified venting must be used at all times. Vent cap should be installed in situations where downdrafts occur. All venting must correspond with the CSA B149 standard or in its absence, local codes.

FV SERIES CONSTRUCTION HEATER – VENTING REQUIREMENTS

1. VERTICAL FLUE TERMINATIONS

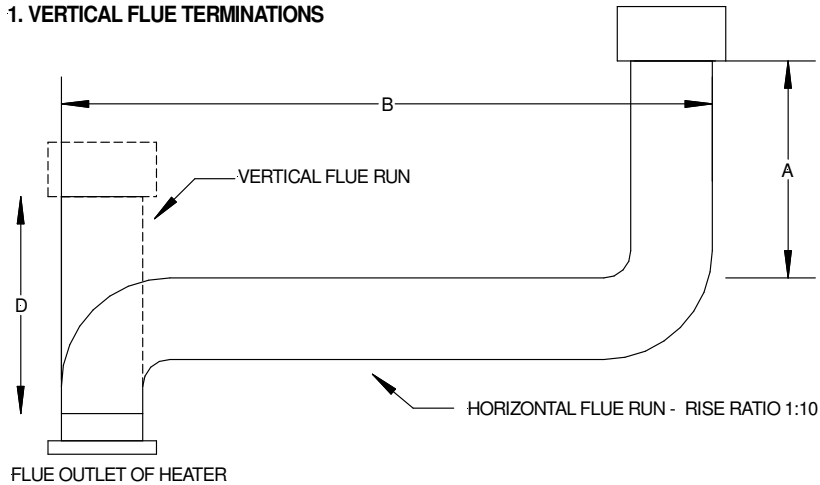

2. HORIZONTAL FLUE TERMINATIONS

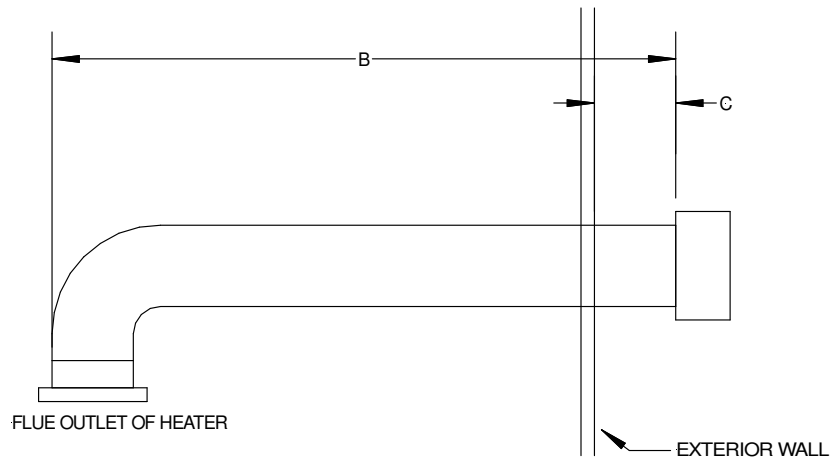

- A - VENT TERMINATION MUST BE A MINIMUM OF 2FT HIGHER THAN ANY POINT WITHIN 10FT.
- B - MAXIMUM HORIZONTAL RUN IS 30FT.
NOTE: 90deg ELBOW = 10ft HORIZONTAL VENT ALLOWANCE
45deg ELBOW = 5ft HORIZONTAL VENT ALLOWANCE
- C - VENT TERMINATION IN HORIZONTAL POSITION MUST BE MINIMUM 4ft FROM ANY COMBUSTABLE SURFACE
- D - EXTERIOR VERTICAL VENT TERMINATION MUST BE A MINIMUM OF 2ft.

NOTE: ALL VENT TERMINATIONS MUST HAVE A RAIN CAP INSTALLED AS PER LOCAL CODE REQUIREMENTS.

MAINTENANCE:

1. **Every construction heater should be inspected before each use, and at least annually by a qualified service person. Incorrect maintenance may result in improper operation of the heater and serious injury could occur.**
2. Service and maintenance should only be done by a qualified service person.

The hose assemblies shall be visually inspected prior to each use of the heater. If it is evident there is excessive abrasion or wear, or the hose is cut, it must be replaced prior to the heater being put into operation. The replacement hose assembly shall be that specified by the manufacturer.

3. The appliance must be kept clear and free from combustible materials, gasoline and other flammable vapors and liquids.
4. The flow of combustion and ventilation air must not be obstructed. Be sure to check the fan assembly and ensure that the motor and blade are operating properly.
5. Compressed air should be used to keep components free of dust and dirt build up. Note: Do not use the compressed air inside any piping or regulator components.
6. Fan Limit Switch (Part# FV-407A) should be replaced if the fan motor does not shut off after the heat exchanger has cooled down.
7. High Limit Switches (Part# FV-406 and FV-437) should be checked each season. These limit switches will ensure the burner shuts down if the temperature exceeds 150°F degrees at rear of unit and 250°F at the outlet.
8. Heat Exchanger should be cleaned if smokey conditions continue even after the air adjustments on the burner are made.

START UP INSTRUCTIONS:

1. Be sure the switch is in the "OFF" position.
2. Ensure electrical cord is grounded and heater is on a level surface.
3. Plug in supply cord to 115v, 15amp outlet.
4. Move switch to "MANUAL" position for manual control.
5. Move switch to "THERMOSTAT" position for thermostatic control.

Please Note:

1. If using Thermostat on unit, unit must be started in Thermostat position.
2. When changing between manual and thermostat operation, the heater must be left in the "OFF" position for 30 seconds to prevent the burner from locking out.
3. When using a generator for electrical supply, make sure the generator is properly grounded and generator is at a 60Hz frequency.
4. In the event that a generator is being used and the generator runs out of fuel, make sure the heater switch is in the "OFF" position before restarting generator, failure to do so may damage heater.

TO SHUT DOWN:

1. Close main gas supply valve while heater is operating.
2. Move switch to "OFF" position.
3. Disconnect heater from gas supply.

NOTE: Fan will continue to operate after the burner shuts down. Once the unit cools down, the fan will stop.

IF HEATER FAILS TO START:

1. Press manual reset button at rear of burner.
2. Check gas pressure supply. Supply and manifold pressure must follow those on rating plate.
3. Ensure proper power supply and extension cord is being used.
4. If heater fails to ignite after 3 attempts, call your supplier for service.

SAFE OPERATION PRECAUTIONS:

1. For use with propane or natural gas only. See approval label.
2. Use switch to shut down the heater. Do not try to shut down the heater by unplugging the electrical cord.
3. Do not plug anything other than the thermostat into the "Thermostat" plug.
4. Follow electrical requirements shown on rating plate and/or Electrical requirements section of this manual.
5. Before removing any guards or performing any maintenance, be sure that the main power supply is disconnected.

COMBUSTION AIR ADJUSTMENTS:

NOTE: Proper combustion air adjustment must be achieved using a certified combustion analyzer to ensure complete combustion.

The air adjustment should be made to achieve 10% CO₂ on natural gas and 12% CO₂ on propane.

SETTING THE AIR ADJUSTMENT PLATE

A) Regulation of the combustion air flow is made by adjustment of the manual AIR ADJUSTMENT PLATE (1) after loosening the FIXING SCREWS (2 and 3). The initial setting of the air adjustment plate should be made according to Column 5 in the Burner Set-up Chart.

B) The proper number on the manual AIR ADJUSTMENT PLATE (1) should line up with the SETTING INDICATOR (4) on the fan housing cover. Once set, the air adjustment plate should be secured in place by tightening SCREWS 2 and 3.

C) The final position of the air adjustment plate will vary on each installation. Use instruments to establish the proper settings for maximum CO₂.

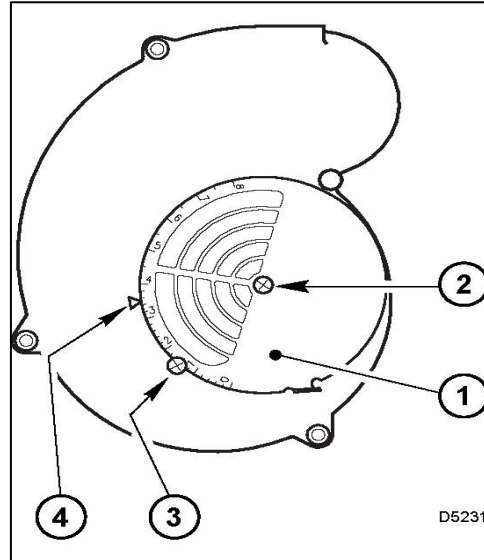

NOTE: Variations in flue gas, CO₂ and temperature readings may be experienced when the burner cover is put in place. Therefore, the burner cover **must** be in place when making the final combustion instrument readings, to ensure proper test results.

BURNER SET-UP CHART

1	2	3	4
FIRING RATE (BTUH)	ORIFICE-NG	HEAD SETTING	AIR DAMPER SETTING
390,000	PART # FVN-426	5	4.8 LP 4.0 NG

TEMPERATURE FEELER GAUGE ADJUSTMENT (ATTACHED TO FAN SWITCH)

The temperature feeler gauge is required to be always touching the heater exchanger.

The temperature feeler gauge controls the air flow over the fan switch, which eliminates any unnecessary fan cycling. The temperature feeler gauge can be adjusted for different outside temperatures, by rotating the location of the temperature feeler gauge holes. This will provide maximum performance of the unit in different applications.

If supply air is warm (-5°C , indoor application):

Turn the temperature feeler gauge so that the holes are parallel with the heat exchanger. This will help the fan switch to remain cool and not overheat. See following:

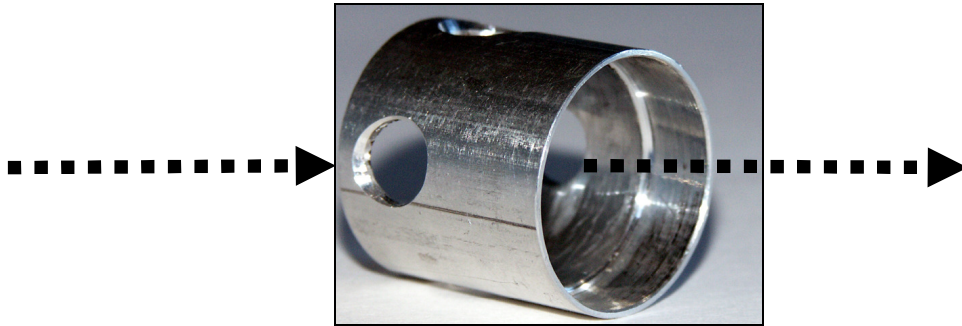

If supply air is cold (under -5°C):

Turn the temperature feeler gauge so that the holes are closed off as the air goes over the heat exchanger. This will reduce fan cycling and the unit from shutting down.

See following:

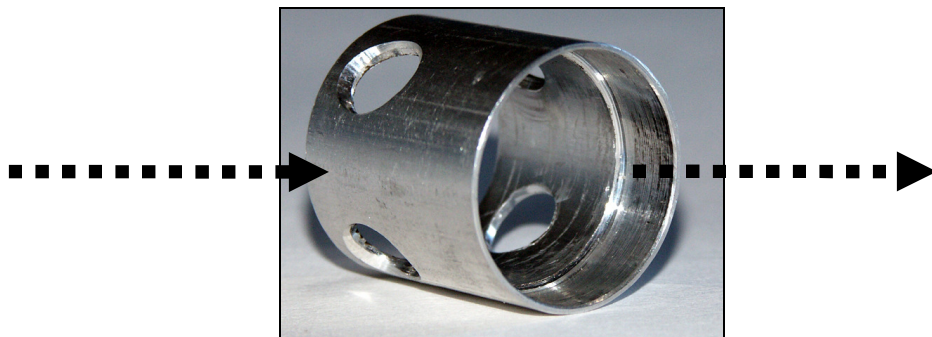

In extreme cold conditions, cover the holes on the temperature feeler gauge using foil tape. Ensure that the temperature feeler gauge is readjusted for warmer weather conditions. Failure to do so may result in burning out fan switches – not covered under warranty.

PRINCIPAL BURNER COMPONENTS

1. Air Damper (Optional Delete)
2. Air Gate Lock-screws
3. Wiring Terminal Block
4. Air Pressure Switch
5. Motor
6. Lockout Lamps and Reset Button
7. Cover Screw
8. Rubber Grommet
9. Capacitor

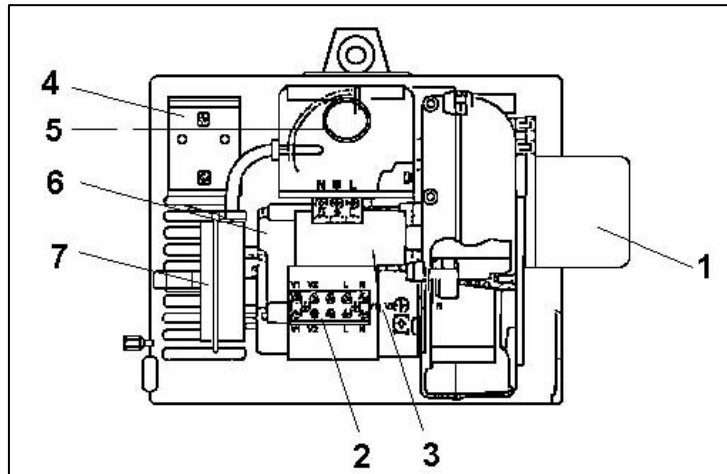

BURNER DIMENSIONS

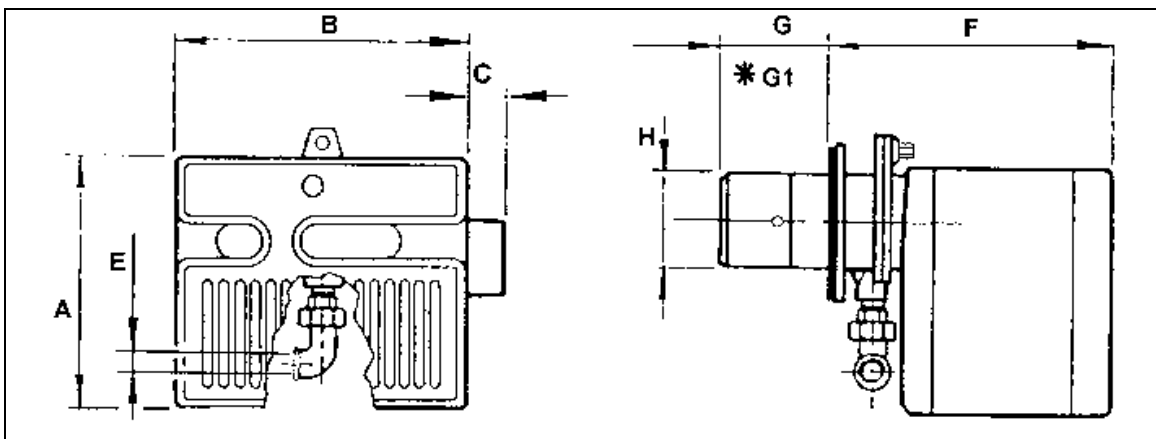

Model 400	A	B	C	F	G	*G1	H
inches	10 5/16	12	1 3/8	13 11/16	3 3/4	10	4 1/8
mm	2262	305	35	347	95	255	61

*G1 is for LBT version
Gasket thickness is 4 millimeters

ELECTRODE AND FLAME PROBE ADJUSTMENTS

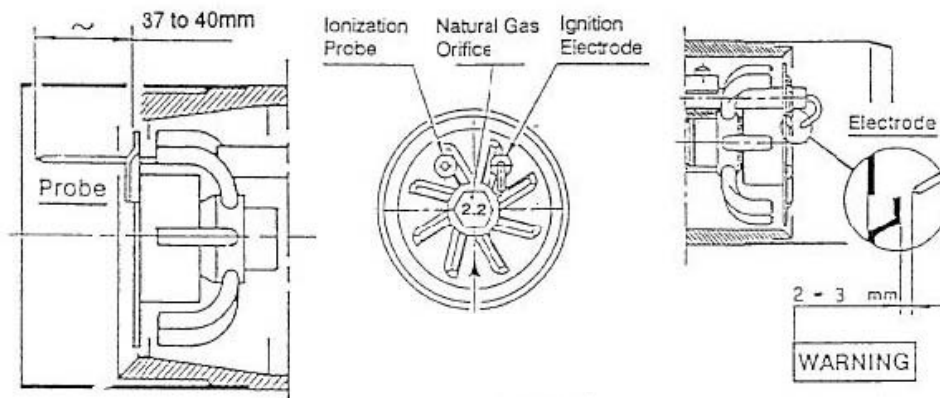

IMPORTANT: Do not turn the ignition electrode. Leave it as shown in the drawing. If the ignition electrode is put near the ionization probe, the amplifier of the control box may be damaged.

TYPICAL GAS TRAIN LAYOUT

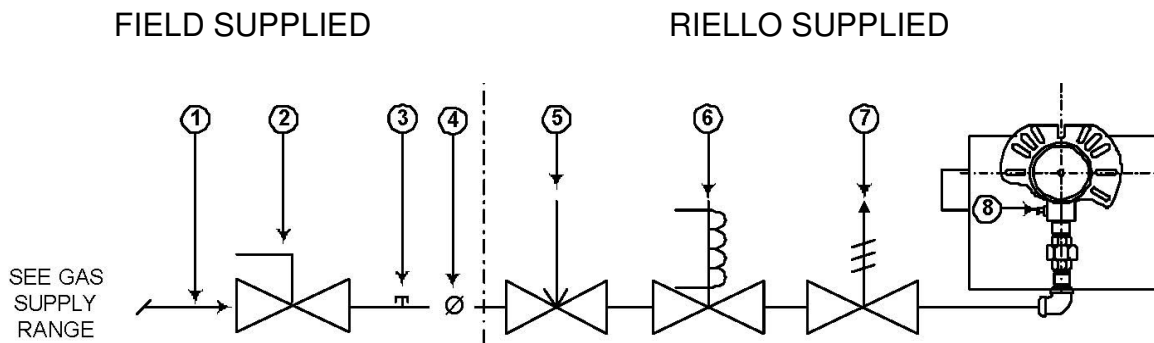

NOTE: ITEMS 5,6 & 7 COMBINATION GAS VALVE(S) ASSEMBLIES MAY BE UTILIZED WHERE APPROVED.

GAS TRAIN LEGEND

- | | |
|---|--|
| <p>1 GAS SUPPLY & FLOW DIRECTION OF GAS</p> <p>2 AS SUPPLY MAIN SHUTOFF MANUAL VALVE (FIELD SUPPLIED)</p> <p>3 GAS SUPPLY PRESSURE TEST POINT (FIELD SUPPLIED)</p> <p>4 GAS TRAIN PIPE DIAMETER SIZE(S):
BURNER G120 1/2" NPT (REDUCED AT COMBUSTION HEAD TO 3/8")
BURNER(S) G200 & G400 3/4" NPT</p> | <p>5 GAS APPLIANCE PRESSURE REGULATOR</p> <p>6 SAFETY SHUTOFF GAS VALVE (VS) 24V OR 120V SUPPLIED) OPERATED</p> <p>7 MAIN GAS VALVE (V1) 24V OR 120V OPERATED SINGLE STAGE</p> <p>8 GAS BURNER MANIFOLD TEST POINT</p> |
|---|--|

GAS SUPPLY PRESSURE RANGES:

NATURAL GAS PRESSURE:

MIN. = 4.0" WC

MAX. 10.0" WC

L.P. PROPANE GAS PRESSURE

MIN. = 8.0" WC

MAX. 13.0" WC

FIELD WIRING DIAGRAM

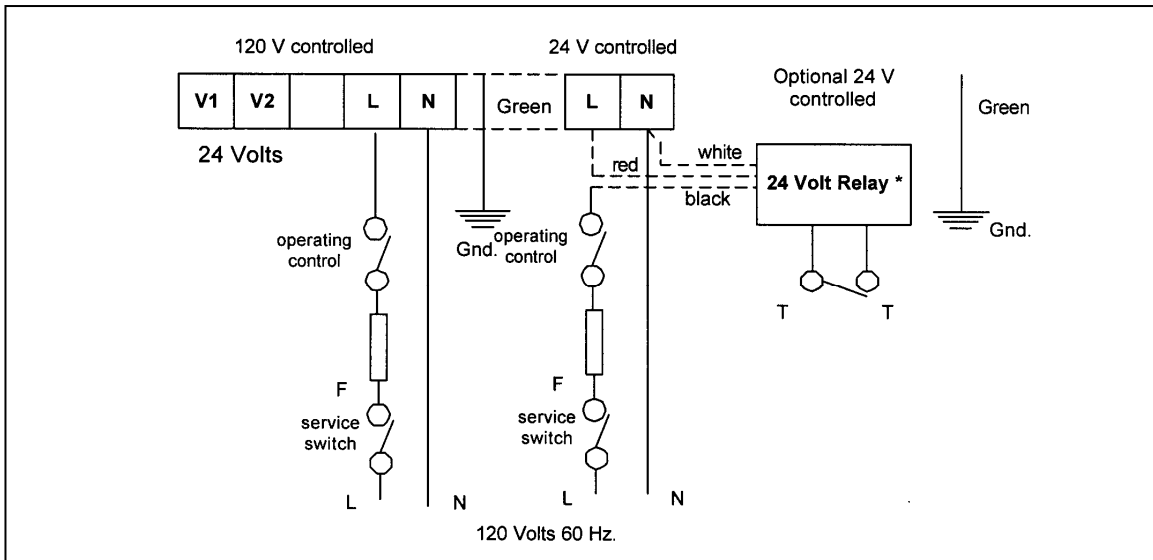

FACTORY WIRING DIAGRAM

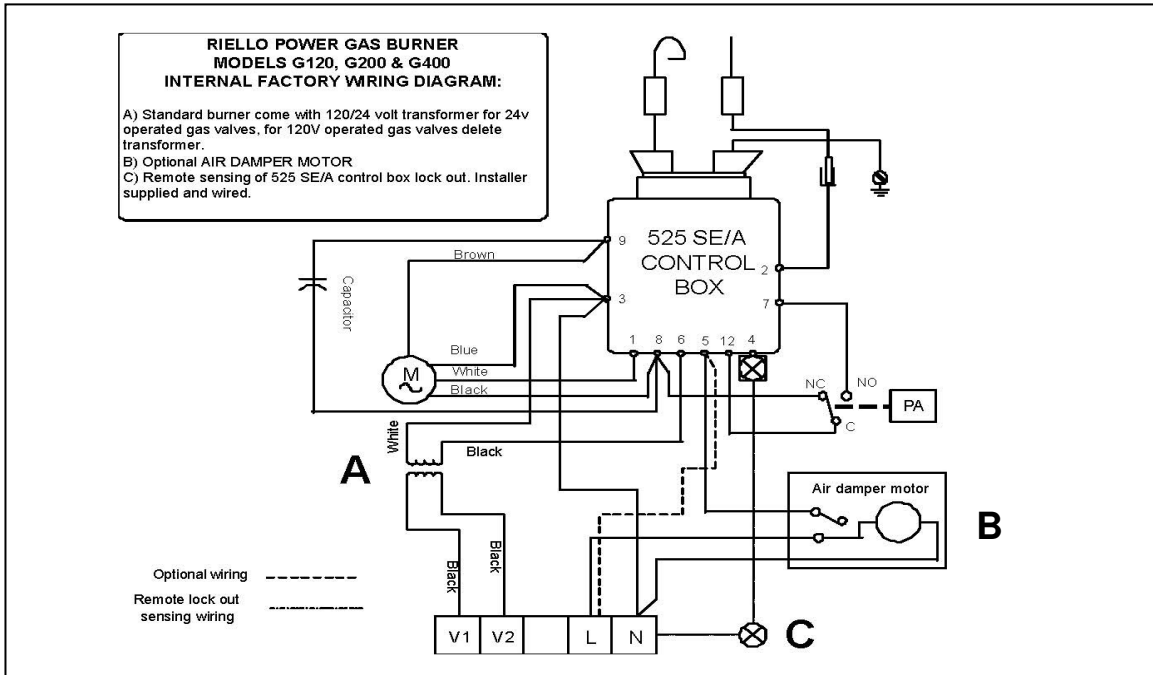

NOTE:

1. This burner is approved for use without the motorized air damper. In these instances optional wiring is used
2. The SAFETY SWITCH on the 525 SE CONTROL BOX is equipped with a contact allowing remote sensing of burner lockout. The electrical connection is located on the CONTROL BOX terminal 4 as indicated. Should burner lockout occur, the 525 SE CONTROL BOX will supply a power source of 120 Vac to the connection terminal. The maximum allowable current draw on this terminal is 1 A.

PARTS LIST FOR FVNP-400RC

Part Number	Part Description	
FV-401A	1 HP FAN MOTOR FOR FVO/FVN/FVP (RC UNIT)	
FV-402RC	16" BC IMPELLER FOR FV-400RC	
FV-402RCA	VENTURI FOR 16" BC IMPELLER	
FV-403	16" WHEEL	
FV-404	18" POWER CORD	
FV-405	SS HEAT EXCHANGER	
FV-406	HIGH LIMIT SWITCH (OUTLET)	
FV-407A	FAN LIMIT SWITCH (ADJUSTABLE)	
FV-407G	FAN LIMIT SILICONE GASKET	
FV-408RC	RECIRCULATING FAN MOTOR CANOPY FOR FVO/FVN/FVP	
FV-408IFP	CANOPY INNER FACEPLATE	
FV-408IR	CANOPY INLET RING	
FV-P01RC	TOP BODY PANEL	
FV-P02	BOTTOM BODY PANEL	
FV-P04RC	REAR BURNER MOUNT PANEL	
FV-P05RC	MOTOR MOUNT BRACKET	
FV-P08RC	CONTROL BOX	
FV-P09RC	CONTROL BOX LID	
FV-P10	LIMIT BOX (DOUBLE HOLE)	
FV-P11	LIMIT BOX (SINGLE HOLE)	
FV-P12	LIMIT BOX LID	
FV-409	TOGGLE SWITCH (ON CONTROL BOX)	
FV-411	RED LIGHT (ON CONTROL BOX)	
FV-414B	THERMOSTAT PLUG (ON CONTROL BOX) 2011>	
FV-415A	MALE CONNECTOR FOR FV-THB	
FVNP-424	RIELLO BURNER	
40-100-12	SCH 40 ELBOW (3/4")	
FVNP-427	MAXITROL REGULATOR (RV52)	
FVNP-429	ASCO SOLENOID VALVE	
FVNP-430	VALVE ASSEMBLY MOUNTING BRACKETS (2)	
FV-431	BURNER GASKET	
FV-433	FEELER GAUGE	

FV-433B	FEELER GAUGE - SOLID	
FV-434CB12	FRONT FACE PLATE (2 X12")	
FV-434CB16	FRONT FACE PLATE (1 X16")	
FV-437	HIGH LIMIT (REAR)	
FV-438RC	LIFTING HARNESS	
FV-446	SIGHT GLASS C/W FIBER GASKET	
FV-447	SIGHT GLASS WASHER	
FV-448	MAIN RELAY	
FV-450SI	SMART INDICATOR	
FV-469	120V LED VOLT METER	
FVNP-3000870	HINGE ASSEMBLY	
FVNP-300162	IGNITION MODULE	
FVNP-3002307	G400 BURNER SUB-BASE	
FVNP-3005447	GAS PRESSURE TEST POINT ADAPTER	
FVNP-3005834	CAPACITOR	
FVNP-3006356	MOUNTING FLANGE	
FVNP-3006688	CHASSIS MOUNTING COLLAR	
FVNP-3006699	DISTRIBUTOR HEAD & MIXING PLATE	
FV-20136636	BURNER BACK COVER	
FVNP-3007276	ELECTRODE ASSEMBLY	
FVNP-3007277	FLAME ROD ASSEMBLY	
FVNP-3007288	AIR SWITCH TUBE & CONNECTOR	
FVNP-3007293	AIR TUBE COVER PLATE	
FVNP-3007300	MANIFOLD- LONG	
FVNP-3007310	IONIZATION LEAD	
FVNP-3007448	GROUND LEAD & CONNECTOR FOR BURNER	
FVNP-3020321	AIR PRESSURE SWITCH FOR BURNER	

	ACCESSORIES	
FV-HD12	12" X 12-FT HITEX DUCTING	
FV-HD12X25	12" X 25-FT HITEX DUCTIND	
FV-HD16x25	16" X 25-FT HITEX DUCTING	
FV-THB	THERMOSTAT C/W 25FT CORD/FEMALE PLUG END - as of 2011	
FVN-426	REPLACEMENT ORIFICE	
FV-VK	6" X 3FT C-VENT C/W RAIN CAP	

FVNP-400RC WIRING DIAGRAM

