

Bronze Marine Pumps

- **Bronze Construction**
- **Buna-N Mechanical Seal and O-Ring**
- **Maximum Working Pressure 50 PSI**
- **Maximum Temperature 180° F**
- **Maximum Flow 17 GPM**
- **Maximum Head 12 Ft.**
- **Self-Cleaning, Semi-Open Impeller**
- **Totally Enclosed Motors**
- **12 Volt DC or 115 VAC Motor, Depending on Model**

Model 3670-94
3/4" x 1/2"

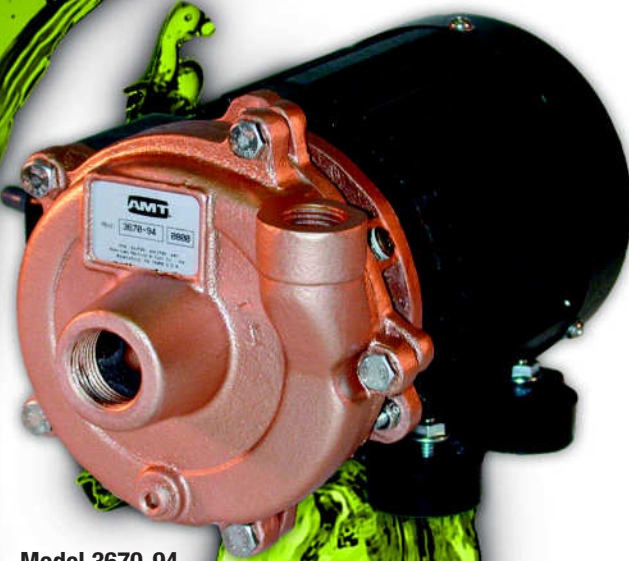

Model 4860-97
3/4" x 3/4"



The AMT Model 3670-94 Naval Bronze Straight Centrifugal pump is designed for low pressure salt water wash down and recirculating applications. The pump has been sized for salt water (1.03 specific gravity) and feature provisions for the installation of a seal wash, front drain plug and pull-from-rear design. The unit is driven by a 1/8 HP capacitor start induction motor (TEFC) with ball bearings and a stainless steel shaft. On/off switch and line cord are standard.

The AMT Model 4860-97 Bronze Centrifugal pump is compact and designed for use in general dewatering, salt water applications in live well tanks, circulation and chemical transfer. This pump is fitted with a 1/8 HP, 12 Volt DC, 3700 RPM motor. **Pumps are not self-priming and require flooded suction.**

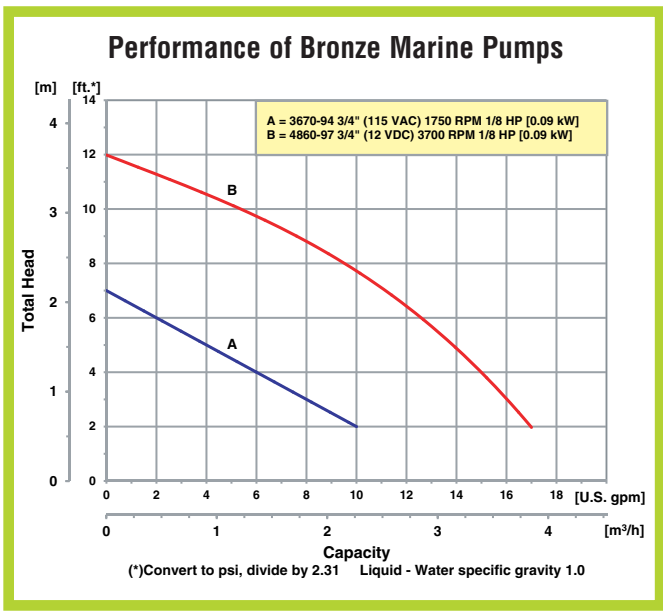

400 Spring Street • Royersford, PA 19468 USA
www.amtpump.com • 888-amt-pump (268-7867)

For use with nonflammable liquids compatible with pump component materials. Viton® and Teflon® are registered trademarks of E. I. DuPont.

Pump Dimensional & Specification Data

Model 3670-94

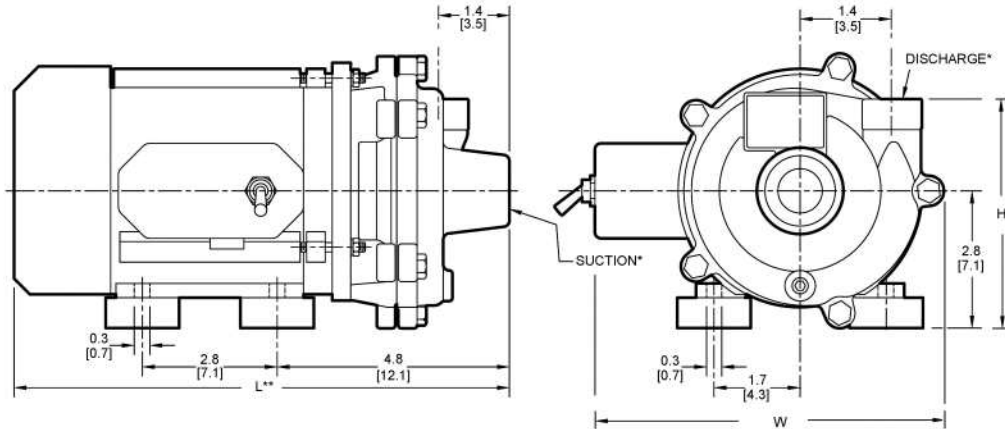

Model 4860-97

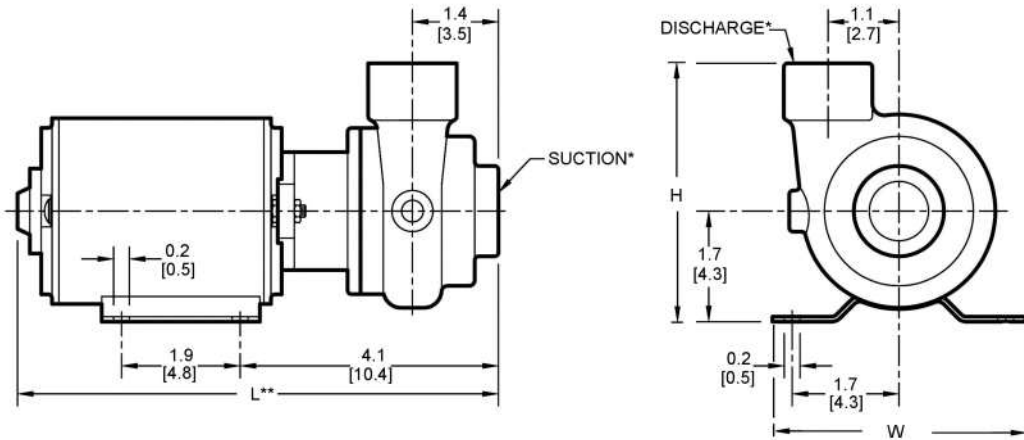

Model	Curve	HP	PH	RPM	ENC	Voltage @ 60 Hz	Full Load Amps	SUC*	DIS*	L**	W	H	Ship Wt. (Lbs.)
4860-97	B	1/8	-	3700	TENV	12.8V DC	9	3/4	3/4	7.6 [19.3]	3.3 [8.3]	4.0 [10.1]	7
3670-94	A	1/8	1	1750	TEFC	115	11	3/4	1/2	10.1 [25.5]	8.0 [20.3]	5.6 [14.2]	20

(*) Standard NPT (Female) pipe thread.

(**) This dimension may vary due to motor manufacturer's specifications.

NOTE: Dimensions are in inches [centimeters] and have a tolerance of $\pm 1/4"$.

NOTE: Electric supply for ALL motors must be within $\pm 10\%$ of nameplate voltage rating (e.g. 230V $\pm 10\%$ = 207 to 253).

Maximum Solids Handling Capacity:

3670-94 – 1/8" Diameter

4860-97 – 3/16" Diameter

Standard Features

- Bronze Construction
- Buna-N Mechanical Seal and O-ring
- Maximum Working Pressure 50 PSI
- Maximum Temperature 180° F
- Maximum Flow 17 GPM
- Maximum Head 12 Ft.
- Self-cleaning, Semi-open Impeller
- Totally Enclosed Motors
- 12 Volt DC or 115 VAC Motors
- QSP – Quick Ship Pumps