

## 2" Engine Driven AG/Dewatering Pumps



2" Dewatering Cast Iron Pump



2" Thermoplastic Pump

- **Cast Iron or Thermoplastic Construction**
- **Buna-N or Viton® Mechanical Seal (Depending on Model)**
- **Optional Seals Available**
- **2" NPT Port Size**
- **Self-Priming up to 20 Ft.**
- **Semi-Open, Clog Resistant Impeller**
- **Engine Options: Honda and Briggs & Stratton**
- **Carry Handle Included**
- **Heavy Duty Steel Base Installed on Cast Iron Models**
- **Built-in Check Valve**

The AMT line of Engine Driven Dewatering pumps offers economy, durability, portability and performance all in one neat package. Ideal for general purpose dewatering, irrigation, spraying, washdown and agricultural applications. Cast iron pumps feature dual volute design that reduces radial load on engine. Built-in check valve enables constant self-priming to 20 feet. Pump construction materials available in cast iron or corrosive resistant polypropylene components featuring removeable/replaceable volute and impeller. Pumps are available with Briggs & Stratton or Honda engines. Viton®, EPDM and Silicon Carbide mechanical seal options are available on specific models.

Performance of Engine Driven Dewatering Pumps

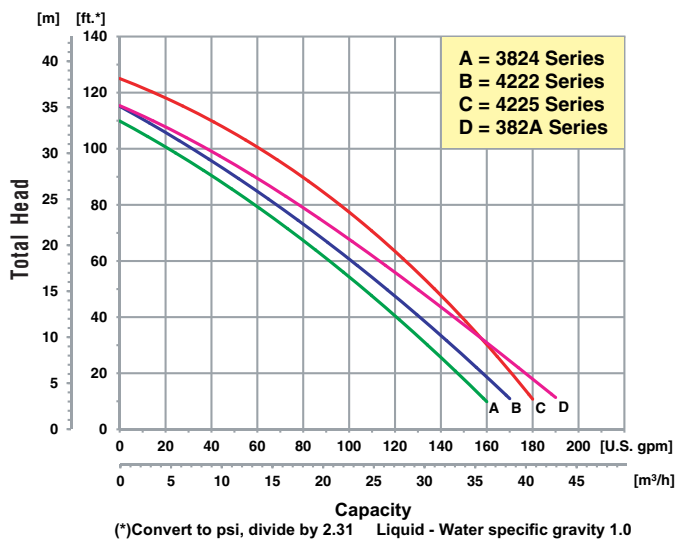

400 Spring Street • Royersford, PA 19468 USA

[www.amtpump.com](http://www.amtpump.com) • 888-amt-pump (268-7867)

For use with nonflammable liquids compatible with pump component materials. Viton® and Teflon® are registered trademarks of E. I. DuPont.

## 2" Cast Iron AG/ Dewatering Pumps

Model	Curve	Port	Driver	Seal	Run Time (Hours)	Tank Size (Gal./Ltr.)	Ship Wt. (Lbs.)
4222-95	B	2" NPT	Briggs & Stratton	Buna-N	1.2	0.52/2.0	65
4222-V5	B	2" NPT	Briggs & Stratton	Viton®	1.2	0.52/2.0	65
4225-95	C	2" NPT	Honda GC160	Buna-N	1.5	0.47/1.7	70
4225-V5	C	2" NPT	Honda GC160	Viton®	1.5	0.47/1.7	70

Construction: Cast Iron

Maximum Solids Handling Capacity: 3/8" Diameter

### Standard Features

- (2) NPT Pipe Nipples
- Buna-N or Viton® Mechanical Seal, Depending on Model
- Optional Silicon Carbide Mechanical Seals
- Built-in Check Valves
- Fiber Gasket Casing Seal
- Self-primes to 20 feet
- Semi-open, Clog Resistant Impeller
- Engine Shaft Protected with Stainless Steel Shaft Sleeve
- Maximum Temperature 180° F
- Maximum Working Pressure 75 PSI
- Delivers a Maximum of 180 GPM
- Dual Volute Design
- QSP – Quick Ship Pumps

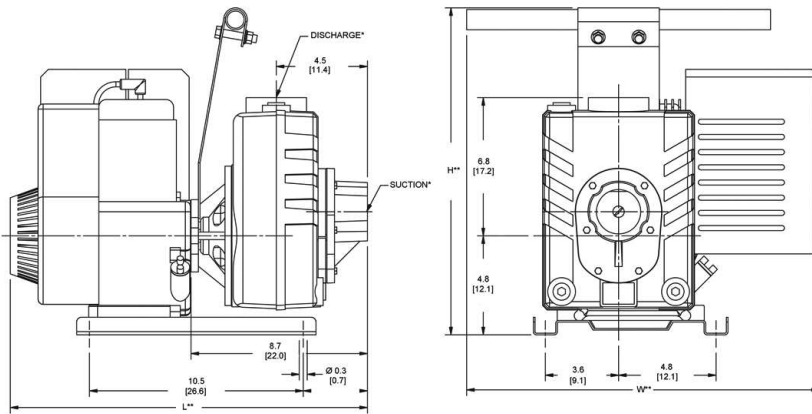

## 2" Thermoplastic AG/ Dewatering Pumps

Model	Curve	Port	Driver	Seal	Run Time (Hours)	Tank Size (Gal./Ltr.)	Ship Wt. (Lbs.)
3824-99	A	2" NPT	Briggs & Stratton	Buna-N	1.2	0.52/2.0	40
382A-99	D	2" NPT	Honda GC160	Buna-N	1.5	0.47/1.7	45

Construction: Polypropylene

Maximum Solids Handling Capacity: 7/16" Diameter

### Standard Features

- (2) NPT Pipe Nipples
- Buna-N Mechanical Seal and Check Valve
- Optional EPDM Seal Kit Available
  - O-ring Casing Seal
  - Self-primes to 20 feet with Built-in Check Valve
  - Replaceable Volute
- Maximum Temperature 130° F
- Maximum Working Pressure 60 PSI
- Delivers up to 48 PSI with a Maximum of 190 GPM
- QSP – Quick Ship Pumps

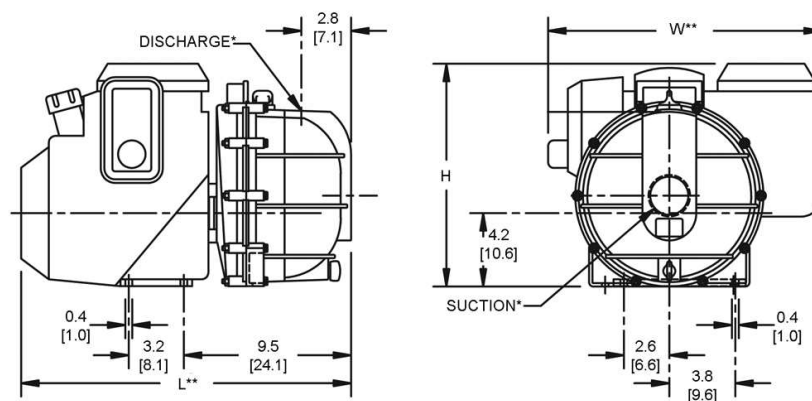

Model	HP Class ♦	SUC*	DIS*	L**	W**	H**
3824-99	4 HP	2	2	18.1 [45.9]	13.6 [34.5]	12.6 [32.0]
382A-99	5 HP	2	2	18.8 [47.7]	15.6 [39.6]	12.7 [32.2]
4222 Series	4 HP	2	2	17.8 [45.2]	17.5 [44.4]	16.1 [40.8]
4225 Series	5 HP	2	2	16.1 [40.8]	19.4 [49.2]	16.1 [40.8]

♦ HP Class represents market category and is not intended to define actual horsepower.

(\*) Standard NPT (Female) pipe thread.

(\*\*) This dimension may vary due to engine manufacturer's specifications.

NOTE: Dimensions are in inches (centimeters) and have a tolerance of ± 1/8".